Reinforced Concrete Corrosion and Protection

Zeinab A. Etman^c

*Department of Civil Engineering , Faculty of Engineering,
Mnoufiya University, EGYPT.*

Abstract

This paper reports result of a study conducted to assess the effect of some locally produced materials on the protection of reinforcing steel against corrosion. Also the effect of period and the main consequences on mechanical properties of steel and concrete are evaluated. Twenty seven concrete cylinders with dimensions (15 × 30 cm) provided with central steel bar were cast and tested after 28 days to demonstrate the effect of the protective materials on the bond strength. A total of ten reinforced concrete beams (10 × 15 × 100 cm) were cast using a self-compacted concrete mix. All beams were tested in flexure. The results of the tested beams are analyzed in terms of; cracking pattern, load deflection, ductility. The tests recommended determining the mechanical properties of mix were; the compressive test, the splitting tensile test, and flexural strength test. Results cleared that with increasing duration of exposure to a corrosive environment, the steel mass loss increases appreciably. This leads to a significant increase of the applied stress. In addition, a reduction of the tensile ductility of the material was observed. The main result from the accelerated corrosion tests in bare steel bars, that the important ductility property of the elongation to failure is very sensitive to mass loss due to corrosion, it is valid and in real structures. Coating with epoxy resin increases the protective from the corrosion more than cement-based resin by 15 %.

Keywords: Self-compacted concrete- ductility - yield stress- ultimate stress-bond strength- corrosion

1. Introduction

Resistance of rebar against corrosion depends upon its chemical composition. Corrosion of rebar in reinforced concrete structure is a complex phenomenon. Corrosion of steel occurs due to a number of initiating causes that expose the rebars to moisture and oxygen either by carbonation or chloride intrusion. During the process of cement hydration, a thin protective

^ccorresponding Author: Zeinab A. Etman

E-mail: dr_zeinab_2006@yahoo.com

Telephone: +201009727355

Fax: +20482238232

© 2009-2012 All rights reserved. ISSR Journals

Alkaline passive film is formed around rebar. Corrosion process is initiated when this protective film is broken. Though good quality concrete is a pre-requisite for the corrosion resistance of RC structure, the quality of rebar has also a significant influence on it. Reinforced concrete is a versatile, economical and successful construction material. It can be moulded to a variety of shapes and finishes. Usually it is durable and strong, performing well throughout its service life. However, sometimes it does not perform adequately as a result of poor design, poor construction, inadequate materials selection, a more severe environment than anticipated or a combination of these factors. The corrosion of reinforcing steel in concrete is a major problem facing civil engineers and surveyors today as they maintain an ageing infrastructure. Potentially corrosion rehabilitation is a very large market for those who develop the expertise to deal with the problem. It is also a major headache for those who are responsible for dealing with structures suffering from corrosion. Reinforced concrete structures have the potential to be very durable and capable of withstanding a variety of adverse environmental conditions. However, failures in the structures do still occur as a result of premature reinforcement corrosion. Corrosion of reinforcement has been established as the predominant factor causing widespread premature deterioration of concrete construction worldwide, especially of the structures located in the coastal marine environment. The most important causes of corrosion initiation of reinforcing steel are the ingress of chloride ions and carbon dioxide to the steel surface, [1-4]. The corrosion process that takes place in concrete is electrochemical in nature, very similar to a battery. Corrosion will result in the flow of electrons between anodic and cathodic sites on the rebar. Practical experience and observations suggest that, although many RC structures are seen as badly deteriorated, characterized by mass concrete cracking and spalling, they are still structurally sound. The reason for this is attributed to the nature of the problem; the corrosion products exert an expansive stress on the concrete the tensile strength of which is usually low. It is also partially due to the fact that the safety factors used in structural design for strength are usually larger than those for serviceability since the paramount importance of structural safety. As a result, the corrosion affected RC structures are more prone to cracking, increasing considerable costs of repairs and inconvenience to the public due to interruptions, [5 and 6]. Reinforced concrete is widely used around the world. Steel bars are used to strengthen a material that would otherwise be brittle. Corrosion of steel bars can reduce a structures mean time before failure. An adequate corrosion control method must be applied for the steel in concrete. Most of the available studies on the corrosion of reinforcing steels refer to the metallurgical aspects of corrosion such as the mass loss, the depth and the density of pitting, [7 and 8]. It is worth noting that the corroded steel bars are located in a zone of high tensile or shear stresses. Maslehuddin et al. [9] evaluated the effect of atmospheric corrosion on the mechanical properties of steel bars. They concluded that for a period of 16 months of exposure to atmospheric corrosion, rusting had an insignificant effect on the yield and ultimate tensile strength of the steel bars. On the other hand, Almusallam [10] evaluated the effect of the degree of corrosion of the steel bars in concrete, expressed as percent mass loss, on their mechanical properties. The results indicated a close relationship between the failure characteristics of steel bars and slabs with corroded reinforcement. A sudden failure of slabs in flexure was observed when the degree of reinforcement corrosion, expressed as percent mass loss, exceeded 13%. Thus, an aged reinforced concrete structure during its life span has accumulated damage in the load bearing elements from corrosion damage that suffered. This cumulated damage causes a degradation of the mechanical properties of the reinforcing steel bars. However, this degradation is neglected by the regulations in force, for static rehabilitation of such structures. The principal cause of steel corrosion is the presence of chlorides during the

preparation of the concrete. In several places close to shore, even sea sand is used as an aggregate. Some chemical admixtures, as accelerators, can contain high percentage of chlorides. De-icing salts used during winter time can introduce chlorides to the reinforced steel. The corrosion process caused by chlorides in steel is shown below in Fig. (1), [11]. Steel corrosion in concrete is an electrochemical process where corrosion cells are generated due to differences in electrochemical potentials. Some areas of the bar become anodes, and some cathodes, [12].

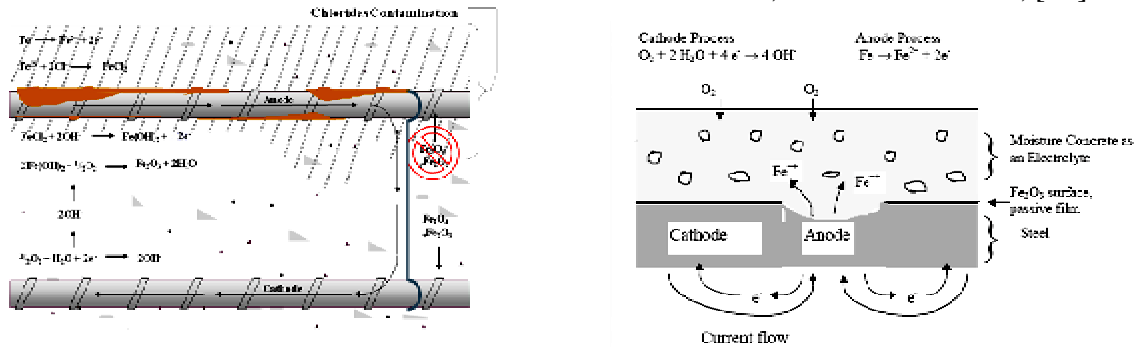

Figure1. Chlorides reinforced steel corrosion, [11] Figure 2. Mechanism of corrosion of steel in concrete, [12]

2. Experimental Study

2.1. Materials

Well graded siliceous sand with a specific gravity of 2.60, an absorption value of 0.78%, and a fineness modulus of 2.61. Coarse aggregate (dolomite) with a nominal size of 10 mm was used, with a specific gravity 2.64 and absorption value of 0.76%. Ordinary Portland Cement (OPC) from Suez factory was used. The cement content was 400 kg/m³ and the water cement ratio was 0.35. Tap water without special taste, smell, color, or turbidity was used for mixing the concrete. A high water reducing admixture with trade name (Sikament NN) was used to allow flowability without segregation. The amount of Sikament NN was 3% of the cement weight. Two percent sodium chloride (NaCl) by weight of cement was mixed in the concrete to facilitate the flow of current in the specimens. Cement-based resin and epoxy resin were used as an anti-corrosive rebar coating. The Swedish Cement and concrete Research Institute (CBI) mix design method was used to design the required trial mixes. The mix properties of this study reported in Table (1).

TABLE 1: MIX PROPORTIONS BY WEIGHT (kg/m³).

	Cement	Dolomite	Sand	Water	Fly ash	Sikament NN
SCC	400	791.8	966	140	40	12

2.2. Casting and testing procedures

The Coarse aggregate (dolomite), the fine aggregate (sand), and the cement used were mixed for at least 1 minute in dry state before the water and admixtures were added. The mixing time after slurry (water, fly ash, and Sikament NN) was added for (3-4) minutes to insure the full mixing of the SCC. The properties of fresh SCC were determined by different methods which included the normal slump test, v-funnel test and

J-ring test. After mixing and removal of concrete from the mixer bowl concrete was placed in the wooden forms

TABLE 2: THE PROPERTIES OF THE FRESH SELF-COMPACTED CONCRETE MIX.

Test Method	Slump flow (cm)		J-ring (mm)			V-funnel Flow (sec)	
	D (cm)	T _{50cm} (sec)	D (cm)	T _{50cm} (sec)	H ₁ -H ₂ (cm)	T (sec)	T _{5min} (sec)
Test Result	67	4.4	65.5	5.97	1.0	8.2	9.88

D: final diameter of the concrete = $[D_1 + D_2] / 2$

T_{50cm}: time for the concrete diameter to reach 50 cm (sec)

H₁-H₂: The difference of the height of the concrete just before and after the ring,

T: Flow-through time (sec)

T_{5min}: Flow-through time after 5 minutes (sec)

TABLE3: MECHANICAL PROPERTIES FOR THE SELF-COMPACTED CONCRETE MIX

Compressive Strength (F _{cu})	35 Mpa
Tensile Strength (F _{sp})	2.05 Mpa
Flexural Strength (F _f)	5.4 Mpa

TABLE 4: DESCRIPTIONS OF EXPERIMENTAL PROGRAM

Beam Code	Description	Corrosion Period (days)
BC	Control Beam	-
BW	Beam Exposed to Corrosion without any Protection	<ul style="list-style-type: none"> • 15 days • 30 days • 60 days
BE	Beam Exposed to corrosion and protected by Epoxy Resin	<ul style="list-style-type: none"> • 15 days • 30 days • 60 days
BS	Beam Exposed to corrosion and protected by Cement Based Resin	<ul style="list-style-type: none"> • 15 days • 30 days • 60 days

2.3 Test Specimens and Test set-up

The experimental program was performance to investigate the efficiency of local protective materials on the corrosion of steel. Reinforcing steel bars were embedded in the concrete specimens with dimensions (15×30 cm) were cast and tested after 28 days to get the bond strength during the duration of corrosion. The nominal diameter of the bars was 10 mm (Ø10). For the cylindrical specimens, the accelerated corrosion was carried out for 15, 30 and 60 days. This was done through an integrated system incorporating a DC

power with a built-in ammeter to monitor the current and a potentiometer to control the current intensity. The concrete specimens were subjected to accelerated corrosion by applying anodic current of specified intensities and for specified time periods, after the process of curing completed. This was achieved through a small DC power supply the concrete specimens were partially immersed in 5% sodium chloride solution in a tank such that the base of the specimen was just in contact with water. The direction of the current was adjusted so that the reinforcing steel became an anode and a stainless steel rod placed on the concrete specimen served as a cathode. Fig. (4) shows the schematic of the test set-up. After the concrete specimens were exposure to the period of corrosion, the concrete specimens were split along the steel bars. The degree of reinforcement corrosion was measured as weight loss of the reinforcing steel bars after cleaning them according to ASTM G1. After that the steel bars were tested in tension to evaluate their mechanical properties. Five specimens from each corrosion period were subjected to the tensile tests and the mean values are reported. The mechanical properties of the steel bars were evaluated using Universal Testing machine of 250 kN capacity. Rectangular reinforced concrete beam specimens of size 10×15×100 cm were used for this research. The reinforcement for the tested beams is shown in Fig. (5). Deformed reinforcing steel bars meeting the requirements of Egyptian Standard Specification were utilized in the concrete specimens.

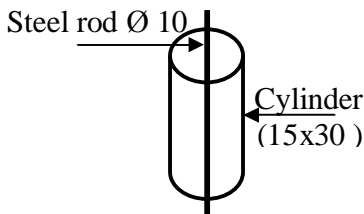

Figure 3. Bond test specimen

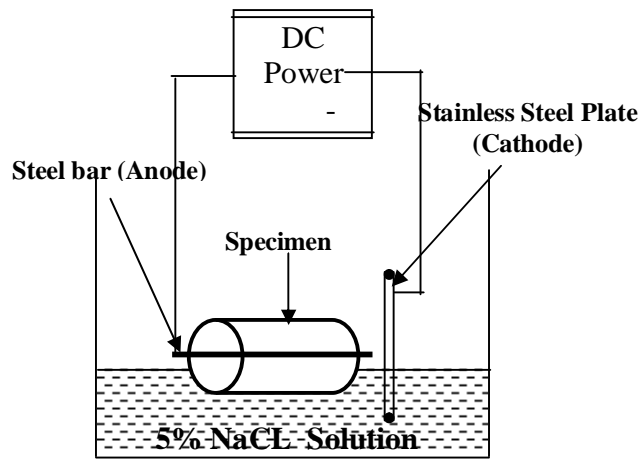

Figure 4. Schematic of the accelerated corrosion test set-up

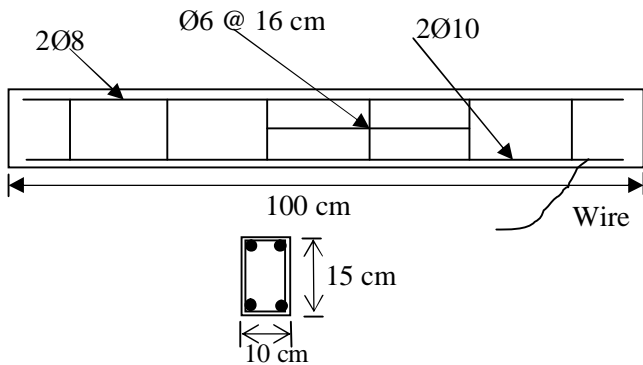

Figure 5. Reinforcement details of test specimens

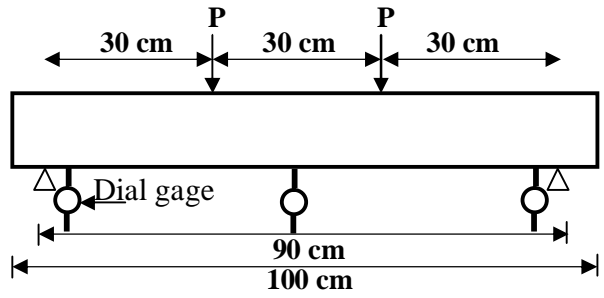

Figure 6. Set-up for four point test of beam specimens

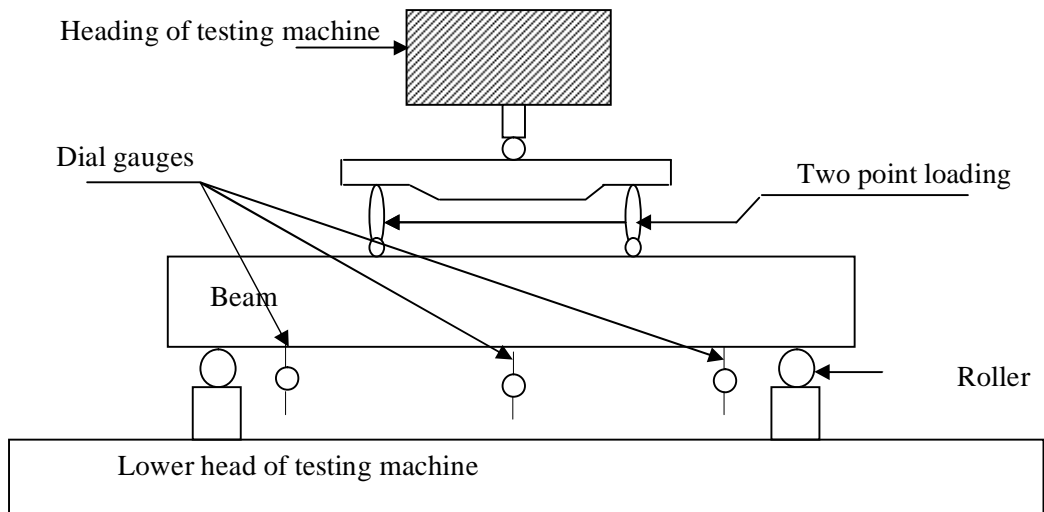

Figure 7. Testing machine and test set-up

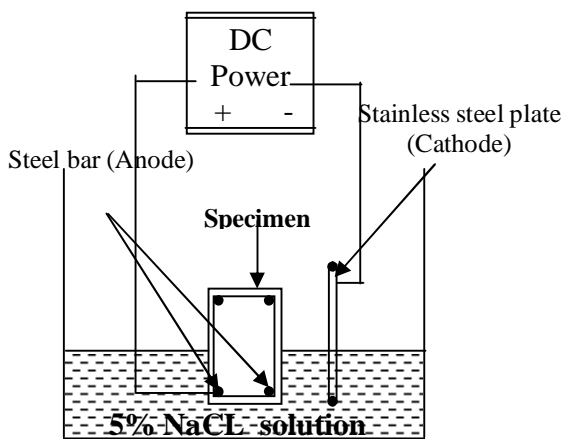

Figure 8. Schematic of the accelerated corrosion test set-up for beams



Figure 9. Photo for the beams during exposed to corrosion

3. Analysis and discussion of test results

After the bond test on corroded specimens, the specimens were broken to remove the corroded bars to measure the weight loss due to corrosion. The specimens were washed with clean running water to remove any deposits from their surfaces, and then were air dried. Finally they were weighed to determine the net weight of steel bars. Preparation, removal of the rust oxide layer by using a bristle brush, cleaning and evaluation of weight loss were carried out in accordance with ASTM G1 specification [13]. As expected, corrosion damage increases with increasing exposure time to corrosion. It is noticed that the corrosion attack initiated at the ribs and propagated towards the area between the ribs. The corrosion attack on the specimen surface, increase in dimensions and depth with increasing period of the exposure. The production of the oxide layer is leads to appreciable loss of the specimen mass. Fig. (10) shows the effect of corrosion on weight loss of steel bars. From the figure, the mass reduction can be considered linear with duration of exposed to corrosion. By assuming a uniform production of the oxide layer around the specimens, it can be noticed that, for corrosion duration of 60 days, the mass loss of the corroded specimen is about 40.7 %, 13.5% and 21.5 % for BW, BE, and BS of the mass of the non-corroded specimen.

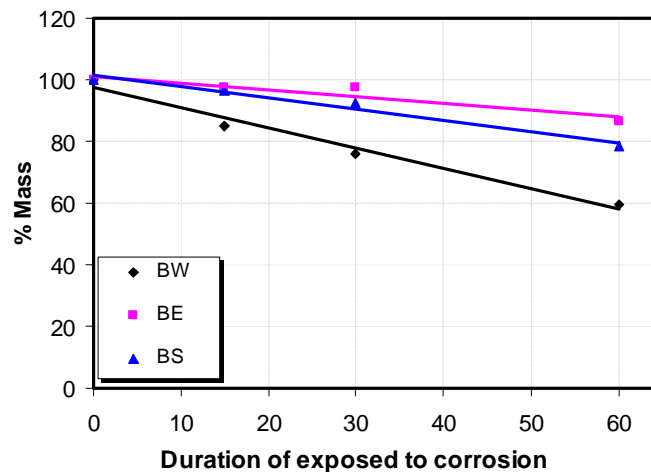

Figure 10. Effect of corrosion on weight of steel bar (Ø 10)

The reduction of nominal diameter (d_r) was measured by Vernier caliper. Fig. (11) demonstrated the reduction of the nominal diameter with the duration of the corrosion. Also the reduced diameter d_r is calculated as: $d_r = \sqrt{a} d$ as shown in Figure (12), where a : is the reduced mass factor and d is the original diameter (10 mm).

In Fig. (13) and (14) the values of yield stress and ultimate stress are illustrated, respectively. As shown in the Fig. (13), the values of yield stress drops below the limit of 360 MPa, which is set by E.S.S, after 15 days of exposure to corrosion for BW only. However the value of yield stress for BE and BS meets the requirement according to E.S.S. As cleared in the Figure (14), the values of ultimate stress drops below the limit of 520 MPa, which is set by E.S.S, after 15 days of exposure to corrosion for BW only. The value of ultimate stress for BE and BS meets the requirement according to E.S.S. It is worth mentioning that even though the actual effect of corrosion on the tensile engineering strength properties of the reinforcing steel is moderate, the corrosion damage problem for the integrity of an older reinforced concrete

structure remains significant [14]. As the loads of a reinforced concrete structure remain the same during the service life of the structure, the reduction of the load carrying cross section of the bars due to corrosion damage results to an increase of the stress applied to the bars. This increase in stress reduces the safety factors taken for the properties of the reinforcing steel. The reduction of the cross-section of a reinforcing bar reduces also the moment of inertia and, hence, the maximum buckling loads of the steel bar. The elongation to failure, as shown Fig. 15, decreases appreciably with increasing duration of the duration of corrosion. The value of elongation to failure meets the requirement 12%, according to the E.S.S, for exposures to corrosion of up to 60 days for BE, and BS, where the bar diameter is reduced only to 9.4 and 9 mm respectively. The value of elongation to failure meets the requirement 12%, according to the E.S.S, for exposures to corrosion of up to 15 days for BW, where the bar diameter is reduced only to 7.23 mm .

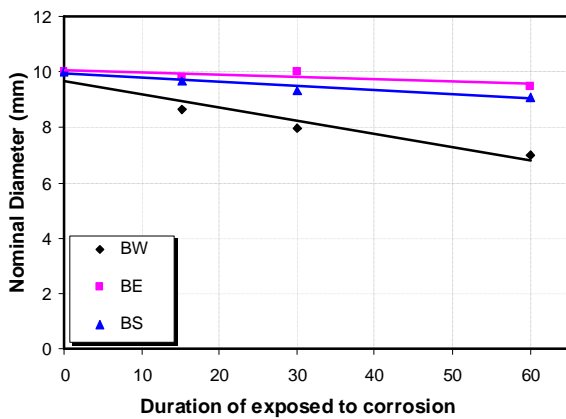

Figure 11. Effect of corrosion on measured nominal diameter of steel bar (Ø 10)

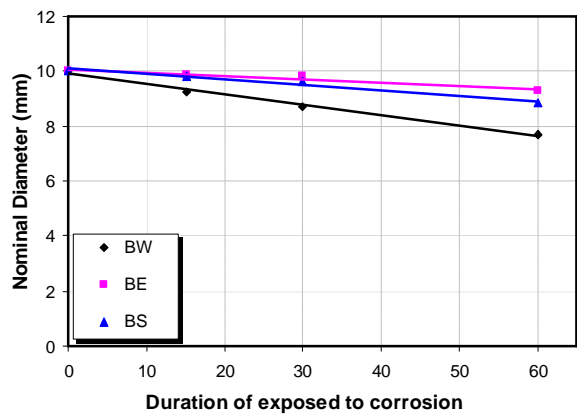

Figure 12. Effect of corrosion on calculated nominal diameter of steel bar (Ø 10)

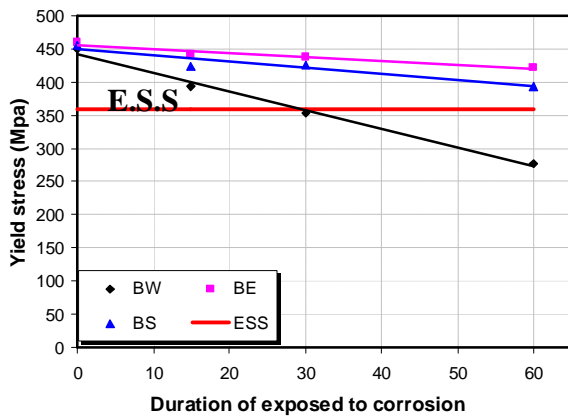

Figure 13. Effect of corrosion on yield stress

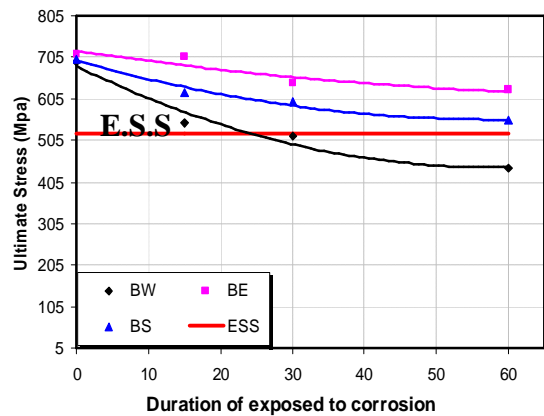

Figure 14. Effect of corrosion on ultimate stress

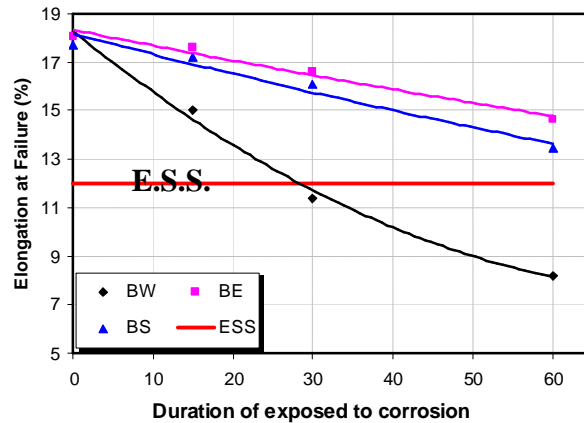

Figure 15. Effect of corrosion on elongation to failure

Fig. (16) the relation between the bond strength and duration of exposed to corrosion are illustrated. The bond strength for specimens' decreases with increased the duration of corrosion. For example the bond strength for the specimen (Bw) was 4.47 Mpa when exposed to corrosion, for 30 days however for 60 days duration of exposure to corrosion duration was 2.91 Mpa for the specimen (BW). For a period of 15 days of exposure to corrosion the bond strength for the specimen was 9.49 Mpa for the specimen (BE), while for the specimen (BS) was 8.45 Mpa for the same period. For the specimen (BS) the bond strength was 6.25 Mpa.

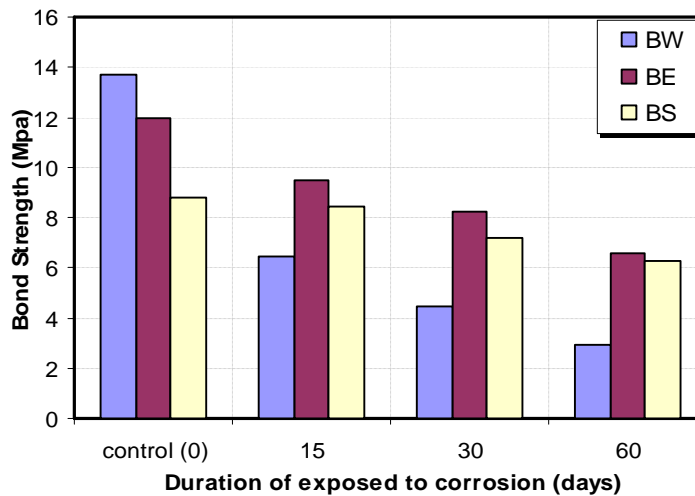

Figure 16. Relationship between bond strength and duration

3.1 Effect of Corrosion on Load-Deflection

Fig. (17) and Fig. (18) show the load-deflection curve for the beams specimens. These figures show that, the results indicate that the corrosion of the reinforcement has a clear effect on the flexural behavior of the concrete beams. Theses figures show also; the deflection of the corroded beams was higher than the deflection of the control beams (BC) which is due to the decline stiffness of the beams. While the specimens were protected

from the corrosion has deflection less than deflection of the corroded beams (BC). For example, at the load of 3 ton, the control beam (BC) recorded deflection of 1.39 mm, compared to 1.64 mm for the beam exposed to corrosion without any protection (BW). The ultimate deflection of the beams decreases with increasing the reinforcement corrosion. This is due to the reduction in the ductility of the beams. These figures show also that the load deflection plots are nearly linear up to 80 percent of the ultimate load. This is loss of stiffness of beams increases with increasing in the corrosion activity. These figures illustrate also, the beams protected by epoxy resin (BE) improved the load-deflection compared to the beams protected by cement based resin (BS). For example, when these beams exposed to corrosion for 15 days the beams (BE) has the behavior nearly close to the control beams (BC) which unexposed to corrosion. When the beams exposed to corrosion for 30 days, also the beam (BE) clear improved in behavior compared the beam (BS) compared to the beam (BW) which is not protected. For example the ultimate load for the beam (BE) was 4.8 ton when exposed to corrosion for 30 days, however for the same duration was 4 ton for the beam (BW). The percentage of the increasing was 20 % nearly. For the beam (BS) the load was 4.2 ton and the percentage of the increasing was 5 %. For a period of 15 days of exposure to corrosion also the increase rate of the load was 14% for the beam (BE), while for the beam (BS) was 5% compared with the beam (BW).

3.2 Effect of corrosion on the ductility

From the Fig. (17) and Fig. (18), it can be noticed that as the corrosion intensity increases the ultimate deflection of the beams decreases. This due to the area under the load-deflection curve decreases. The area under the load-deflection curve is an indicted to the absorbed energy and ductility. So with increasing the corrosion intensity, the absorbed energy and ductility of the beams decreasing. Hence, the corrosion not only affects on the strength of the beams but also brittleness in the behavior of the beams. For example from the Fig. (17) the area under the load deflection for the beam (BW) was decreased by 63.21 % compared to the beam (BC). The area under load-deflection for the beam (BE) was decreased by 54.33% compared to the beam (BC) and increased by 24.1% compared to the beam (BW). For the beam (BS) the area under load-deflection was decreased by 59.33% compared to the beam (BC) and increased by 10.53% compared to the beam (BW). From figure (18) the area under the load deflection for the beam (BW) was decreased by 69.6 % compared to the beam (BC). The area under load-deflection for the beam (BE) was decreased by 55.8% compared to the beam (BC) and increased by 45.17% compared to the beam (BW). For the beam (BS), the area under load-deflection was decreased by 68.4% compared to the beam (BC) and increased by 3.97% compared to the beam (BW). This shows that the reduction in the ductility of beams made with bars corroded to different intensities. Also from theses figures we can notice that the epoxy resin was the best in protecting the reinforcement steel from corrosion compared to cement-based resin.

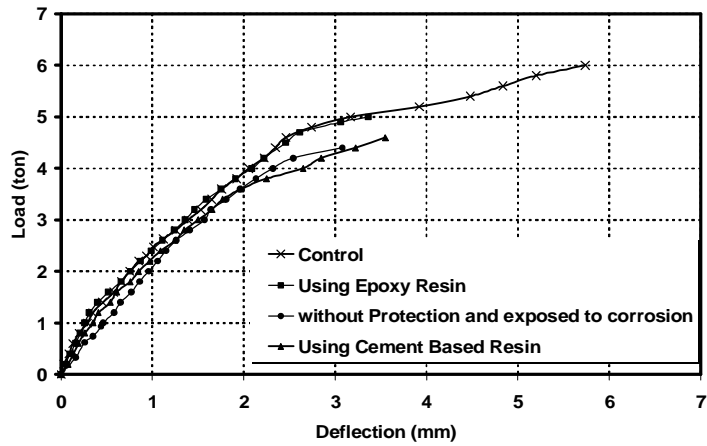

Figure 17. Load-deflection curve for tested beams exposed to corrosion for 15 days

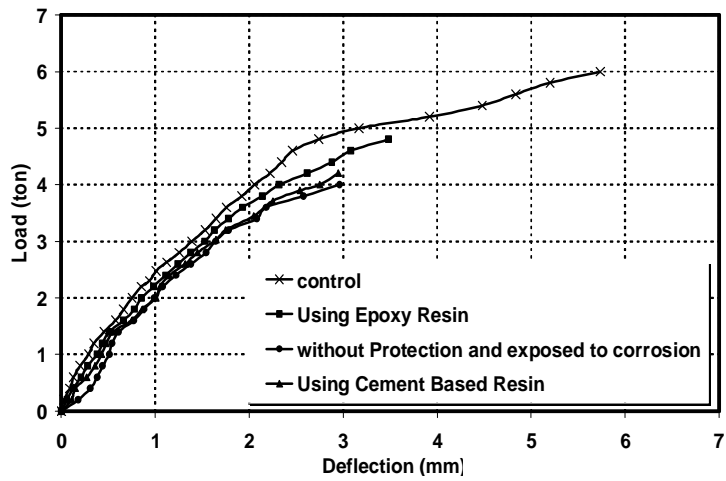

Figure 18. Load-deflection curve for tested beams exposed to corrosion for 30 days

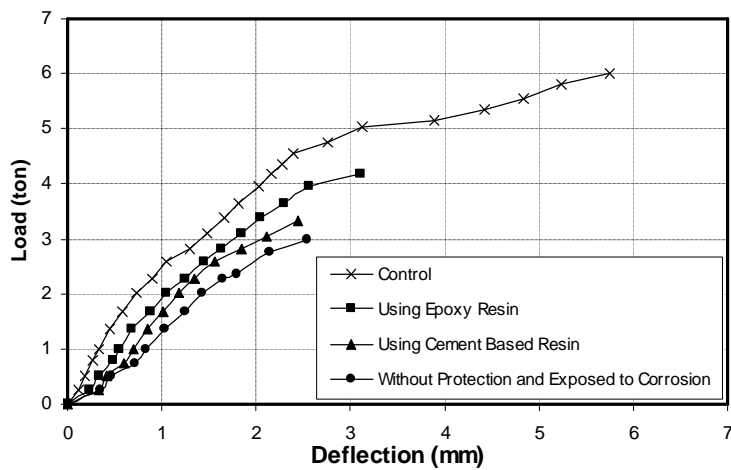

Figure 19. Load-deflection curve for tested beams exposed to corrosion for 60 days

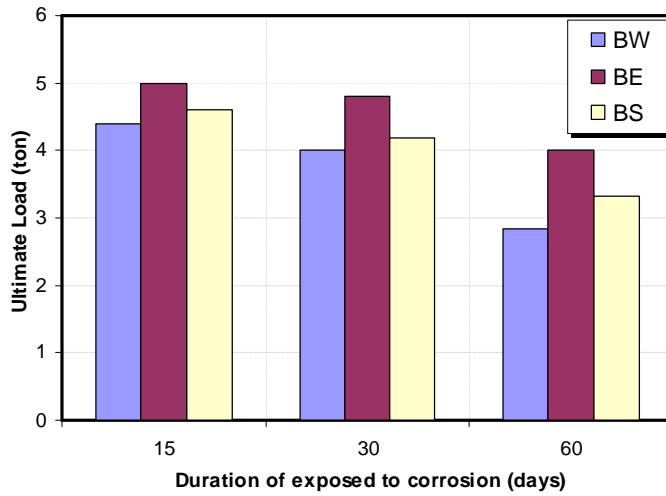

Figure 20. Ultimate load for the tested beams exposed to corrosion

3.4 Mode of failure of control and corroded beams

Fig. (24) to Fig. (32) show the crack pattern in all the beams until the failure. Essentially a flexure or flexure-shear type failure was observed in all the beams, in which the cracks advanced towards the top with new cracks emerging. Failure was assumed to occur when the applied load on the beams began to drop, with increasing mid-span deflection.



Figure 21. Beam (BW) after 15 days of Corrosion Acceleration



Figure 22. Beam (BW) after 30 days of Corrosion Acceleration



Figure 23. Corroded beam after 15 days of Corrosion Acceleration



Figure 24. Crack Pattern for beam (BW) after 30 days of Corrosion Acceleration



Figure 25. Crack Pattern for beam (BE) after 30 days of Corrosion Acceleration



Figure 26. Crack Pattern for beam (BS) after 30 days of Corrosion Acceleration



Figure 27. Crack Pattern for beam (BW) after 15 days of Corrosion Acceleration



Figure 28. Crack Pattern for beam (BE) after 15 days of Corrosion Acceleration

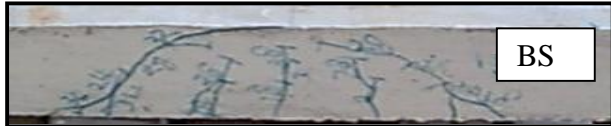

Figure 29. Crack Pattern for beam (BS) after 15 days of Corrosion Acceleration



Figure 30. Crack Pattern for beam (BW) after 60 days of Corrosion Acceleration



Figure 31. Crack Pattern for beam (BE) after 60 days of Corrosion Acceleration



Figure 32. Crack Pattern for beam (BS) after 60 days of Corrosion Acceleration

4. Conclusions:

Based on the test results the following conclusions could be drawn:

1. The accelerated corrosion tests in steel bars, that the important ductility property of the elongation to failure is very sensitive to mass loss due to corrosion, it is valid. A small amount of corrosion despite the fact that has a proportional effect on yield and ultimate stress, it has an exponential effect on elongation to failure.
2. Coating the steel bars with both especial types of epoxy resin and cement-based resin available in the local market demonstrated the efficiency and prevent the corrosion of steel
3. Coating with epoxy resin increases the protective from the corrosion more cement-based resin by 15%.
4. The ultimate deflection of the beams decreases with the increasing of the reinforcement corrosion.
5. The bond strength for the specimen using epoxy resin as a protective material from the corrosion was higher than using cement-based resin.
6. Using the epoxy resin as a protective material from the corrosion improved the ductility of the concrete compared to using the cement-based resin.

References:

- [1] Broomfield J. P., *Corrosion of Steel in Concrete: Understanding, investigation and Repair*, 2nd edition published in Taylor & Francis e-Library, 2003.
- [2] Song H. W. and Saraswathy V., *Corrosion Monitoring of Reinforced Concrete Structures A-Review*, International Journal of Electrochemical Science, 2, 2007, P.P. 1- 28.
- [3] Qian S., *Evaluation of Corrosion Inhibiting Systems Used in Reinforced Concrete*, <http://www.electrochem.org/dl/ma/202/pdfs/0338.PDF>, (Assessed at December 2008)
- [4] Basu P. C., Shylamoni P P. and Roshan A. D. *Characterization of steel reinforcement for RC structures: An overview and related issues* The Indian Concrete Journal, January, 2004 <http://www.sefindia.org/?q=system/files/Steel-reinforcement.pdf>

- [5] Li C.Q., Lawanwisut W., Zheng J.J. and KiJawatworawet W., *Crack Width Due to Corroded Bar in Reinforced Concrete Structures*. International Journal of Materials & Structural Reliability, 3(2) September 2005, P.P 87-94.
- [6] Daily S. F., *Understanding Corrosion and Cathodic Protection of Reinforced Concrete Structures* <http://www.corrpro.com/pdf/CP48.pdf>, (Assessed at December 2008)
- [7] Apostolopoulos C.A. and Papadakis V.G. *Consequences of steel corrosion on the ductility properties of reinforcement bar* Construction and Building Materials 22, 2008 P.P. 2316–2324
- [8] Fang C, Lungren K, Chen L and Zhu. C, *Corrosion influence on bond in reinforced concrete* . Cement and Concrete Research Vol 34 (11) November 2004, P.P. 2159-2167.
- [9] Maslehuddin M., Ibrahim I., Saricimen H and Abdulaziz I. *Influence of atmospheric corrosion on the mechanical properties of reinforcing steel* . Construction and Building Materials Vol 8 (1)1994, P.P. 34-41
- [10] Almusallam AA. *Effect of degree of corrosion on the properties of reinforcing steel bars*. Construction and Building Materials Vol 15 (8) December 2001; P.P. 361-368.
- [11] *Corrosion in Reinforced Concrete*. Eus – Vector, February, 2008, P.P.1-4
- [12] Mehta and Kumar P., *Concrete Structure, Properties, and Materials*, Prentice- Hall, Inc., Englewood Cliffs, N.J. 07632, 1993.
- [13] ASTM G-1, *Standard Practice for Preparing, Cleaning and Evaluating Corrosion Test Specimens*. Annual Book of ASTM Standards, Vol. 01, 2005, American Society for Testing and Materials, Philadelphia, PA.
- [14] Apostolopoulos C. A. and Papadakis V.G., *Mechanical behavior of concrete steel bars of monumental structures*, Journal of materials Engineering and performance. Vol 16 (2) April 2007 P.P 236-241