





Research Article

Structural behavior of shear connectors embedded in different types of concrete

Adil Hadi Wardi ^a , Gokhan Tunc ^{b,*} , Khalil Ibraheem ^c 

^a Ministry of Construction, Housing, Municipalities and Public Works, Anbar, Iraq

^b Department of Civil Engineering, Atılım University, 06830 Ankara, Turkey

^c Department of Civil Engineering, University of Anbar, Ramadi, Iraq

ABSTRACT

Push-out tests are used to determine shear connectors' properties where two small reinforced concrete walls are attached to the top and bottom flanges of an I-section through four shear studs located on both its flanges. In this study, the structural behavior of shear connectors was examined by testing a total of 36 push-out specimens. In these specimens, various test parameters were used. The types of shear connectors and their strengths, their connection types, and the strength of the concrete in which they were embedded were all investigated. Headed, L-shaped, and C-shaped studs were selected in this experimental study to represent different types of shear connectors. These shear connectors were assumed to be either ordinary or high strength steel-embedded in three different types of concrete: ordinary, high strength, and reactive powder concretes. In these tests, the shear connectors were connected through welding or epoxy bonding. The objective of this study was to investigate the structural behaviors of these different types of shear connectors by focusing on their shear force capacities and slip values. The test results indicate that the reactive powder concrete increased the mechanical properties of concrete as the concrete age increased. The specimens with C-shaped studs made of high-strength steel with welded studs embedded in normal weight, high strength and reactive powder concretes, generated the maximum shear resistance values.

ARTICLE INFO

Article history:

Received 11 March 2020

Revised 13 May 2020

Accepted 17 June 2020

Keywords:

Push-out test

Shear connectors

Reactive powder concrete

High strength concrete

1. Introduction

In recent years, composite materials have been frequently used in structures instead of traditional raw materials to attain better mechanical properties that resist various types of loadings subjected to short and long time periods. The goal of using composite material is to increase the overall strength of structural members, thereby achieving more economical cross sections. Therefore, it is important to understand the structural behavior of composite materials and their behaviors. One such material could be a shear connector that works as an interface between a steel and a reinforced concrete member to transfer shear loads resulting from either wind or earthquakes.

Shear connectors were selected as the main focus of this study. The main objective of our research was to investigate the structural behavior of different types of shear connectors embedded in different types of concrete. For this purpose, high strength concrete (HSC), reactive powder concrete (RPC), and no-fine aggregate concrete (NFC) were selected, along with normal weight concrete (NWC), which was used as a reference. Headed studs, L-shaped and channel type shear connectors, assumed to be either welded or epoxy bonded, were also included as an additional parameter in the testing stage.

A total of 36 push-out test specimens were prepared as part of an MS thesis conducted jointly at Atılım University, Ankara, Turkey and the University of Anbar, Ramadi, Iraq, since they have been frequently used in

these types of experiments to assess the interfacial shear strength developed at a composite interface (Wardi, 2019). This interfacial behavior is generally recognized by a load-slip curve that is obtained from experimental push-out tests, even though the tests are generally expensive and time consuming. In this experimental study, the mechanical properties of different types of concrete were also investigated, including their compressive strengths, splitting tensile strengths, modulus of ruptures, moduli of elasticities, and densities.

2. Literature Review

In this section, brief information will be provided regarding the shear studs in various types of concrete.

2.1. Composite behavior of shear studs

Many theories take equilibrium and compatibility equations into account to derive relationships for the composite action of a beam. The earliest theory for composite beams is adopted in 1951 that was based on elastic analysis and linear materials for concrete, steel, and shear stud connectors (Newmark et al., 1951). According to the study, the axial force that was developed between the interface of a steel beam and a composite slab was obtained. In 1968, Adekola derived equations using a finite difference approach that represented the uplift forces and axial forces on a composite beam of steel and concrete (Adekola, 1968).

In the past 20 years, there have been other studies conducted in this area. In 2005, a new model was proposed to explain the performance of multilayer composite slab using partial interaction theory subjected to static loading (Aziz, 2005). Differential equations were derived by applying equilibrium and compatibility equations. Linear and nonlinear analyses of concrete, steel plates, and shear stud connectors were used in simulations taking slip and uplift into account. The unknown variables such as slip, deflection, stresses, and strains were solved at each incremental loading. The push-out test specimens were tested to determine the load-slip relationship, maximum load capacity, and maximum slip value. Validation and verifications to evaluate the actual behavior of a multilayered composite slab were checked with respect to the experimental results.

In 2017, a comprehensive literature review study was conducted to evaluate the shear strength of headed studs in a slab with a steel deck cut on the flange and headed studs in a solid slab (Hirama et al., 2017). For this purpose, headed stud diameter, slab type, and failure modes were investigated specifically for studs with diameters of more than 25 mm. Based on the study, it was found that the shear strength of headed studs with a diameter of more than 25 mm in solid slab decreased gradually with the increasing diameter in both failure modes (headed stud and concrete failures).

The influence of specimen configuration, zirconia surface treatment, and bonding area were evaluated on the push-out bond strength to Y-TZP (yttrium-stabilized

tetragonal zirconia poly-crystal) ceramics using a finite element analysis (FEA) method (Wandscher et al., 2018). Based on the study, it was found that the adhesion increased significantly by surface treatment, except for 'resin cement macro-test'. The FEA method proved that the stresses were more homogeneously distributed at the interface of micro-specimens.

In 2018, the push-out tests of large perfbond connectors, which are commonly used in composite and hybrid bridges, were conducted (Di et al., 2018). For this purpose, 13 groups of 39 push-out specimens were tested to verify the mechanical properties of large connectors. The large sized connectors with their better capacity served as an excellent alternative to the connectors with smaller sizes. The study indicated that the large sized connectors helped to reduce the number of connections, and thus helped the flow of coarse aggregate concrete. The results also showed that the bearing capacity would be improved by increasing the geometrical size of the hole under a high level of concrete dowel confinement. Finally, an empirical formulation to predict the shear capacity was proposed taking multiple influencing factors into account.

2.2. High strength concrete (HSC)

The term "high strength" depends on many parameters, such as the availability of good quality local materials and construction practices. Some of the research conducted in this area is as follows:

In 2017, a total of 280 concrete specimens in 28 different test groups was produced. In this study, the properties of HSC containing silica fume and nano-silica that were both affected by different amounts of polypropylene (PP) and macro-polymeric (MP) fibers were investigated (Fallah and Nematzadeh, 2017). Based on the test results, it was observed that the mechanical properties of high-strength concrete improved by incorporating macro-polymeric fibers into the concrete mixture. The physico-mechanical properties of the HSC were adversely affected when high volume fractions of polypropylene fibers in the concrete mixture was used.

In 2017, a total of twenty-four push-out specimens were investigated to examine the structural behavior of perfbond strip connectors (PBL) for steel-concrete joint of hybrid girders with ultra-high performance concrete (He et al., 2017). In this study, an analytical model for PBL and ultra-high performance concrete was developed, and appropriate parameters from test data were obtained. These parameters were used in the hybrid girders' steel-concrete joints to predict the ultimate resistant-capacity of PBL.

The effectiveness of steel fiber inclusion on the structural performance of HSC columns was examined by conducting a test on a total of 7 specimens with and without steel fiber (Bae et al., 2018). In this study, all test specimens were subjected to axial and reversed cyclic lateral loads. The test results indicated that the steel fiber inclusion not only significantly increased the structural performance of columns, but also increased the shear strength and energy dissipation capacity of the

columns. Based on the test results, a new equation was proposed to estimate the strength of steel fiber reinforced high strength concrete columns.

2.3. Reactive powder concrete (RPC)

Reactive Powder Concrete (RPC) is a developing composite material that produces high strength (both compressive and flexural) and lower permeability compared to High Performance Concrete (HPC). In this section, the most recent literature review on RPC is presented, including laboratory investigations of both RPC and HPC.

In 2013, the behavior of T and rectangular sectioned beams under shear were investigated (Al-Shafi'i, 2013). The beams were subjected to four point loads. The tests focused on recording cracked load, ultimate shear, mid-deflection and crack width. The researcher concluded that increasing the percentage of steel fiber to 2%, increased the cracked load by 60% compared to that of the T section constructed from normal concrete.

Experimental and theoretical works of T-sectioned beam under flexural loading were also investigated (Ismael, 2013). For this purpose, a total of fifteen beams were tested using parameters like steel fiber, silica fume, tensile strength, and geometric cross-section. Crack loads, strength capacity, maximum deflection, and failure modes were the main parameters studied by the author. By using block stress distribution, the author derived an equation to determine the bending moment capacity. The tests result indicated that increasing the RP increased the capacity of the loading.

In another study, I-sectioned beams were examined using both experimental and theoretical works (Hmeed, 2014). The main parameters of the testing were the concrete type and longitudinal steel ratio. The author noted that the behavior of beams under flexure was depended on the type of concrete used in their flanges. The change in concrete type at the top and bottom flanges made changes in the deflection and crack loading by around hundred percent. The test results focused on

crack load, load capacity, mid-deflection, and failure modes. According to the tests, the results indicated an increase in the ratio of RPC caused a rise in the load capacity but a decrease in the deflections.

3. Mechanical Properties of Different Types of Concrete

The properties of different types of concrete used in this study are described in detail in the following sections. The details of each concrete testing has not been included since the focus of this article was on the structural behavior of shear studs. However, the results of the concrete tests have been included for the benefit of other researchers conducting studies in this area (for more information please refer to Wardi (2019)).

3.1. Compressive strength

The compressive strengths of different types of concrete are given in Fig. 1 and Table 1. A total of 60 cube specimens with dimensions of 150 mm by 150 mm by 150 mm were tested.

Based on the test results, the concrete compressive strengths at 28 days were 27 MPa for the normal or ordinary weight concrete (NWC or OWC), 85 MPa for the HSC, 120 MPa for the RPC, and 20 MPa for the no fine concrete (NFC).

3.2. Splitting tensile strength

The splitting tensile strength values of different types of concrete are given in Fig. 2 and Table 2. A total of 40 specimens with dimensions of 400 mm by 100 mm by 100 mm were tested.

Based on the values given in Fig. 2 and Table 2, as expected the maximum value of the splitting tensile strength at 28 days was 14 MPa and obtained for the RPC while the minimum one was 2.0 MPa for the NFC. The same value for the reference concrete, NWC (OWC), was 3.1 MPa.

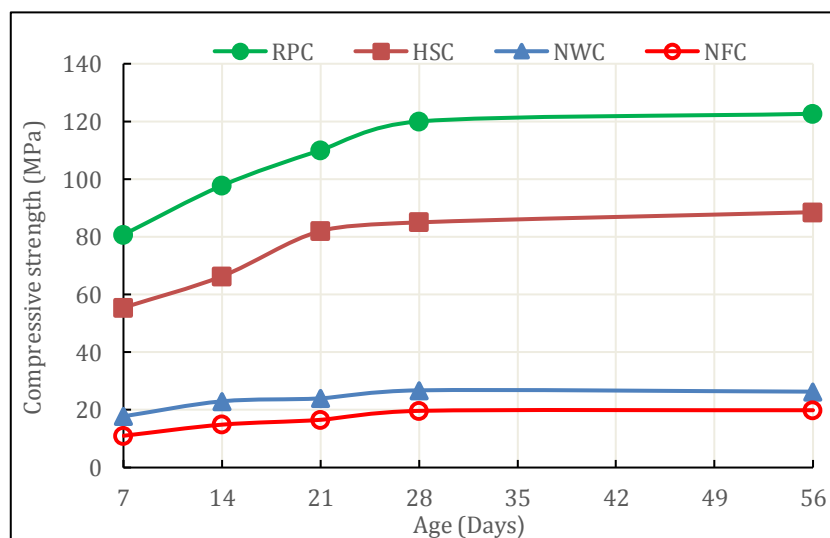

Fig. 1. Compressive strength of different types of concrete.

Table 1. Compressive strength as a function of time.

Type of concrete	Age (days)	Compressive strength (MPa)	Change in compressive strength with respect to reference mix (%)
M1 (NWC or OWC) Reference	7	17.8	0
	14	23.0	0
	21	24.0	0
	28	26.8	0
	56	26.3	0
M2 (HSC)	7	55.4	212
	14	66.3	189
	21	82.0	242
	28	85.0	218
	56	88.5	237
M3 (RPC)	7	80.8	355
	14	97.8	326
	21	110.0	359
	28	120.0	348
	56	122.7	366
M4 (NFC)	7	11.0	-38
	14	14.9	-35
	21	16.5	-31
	28	19.7	-27
	56	19.9	-25

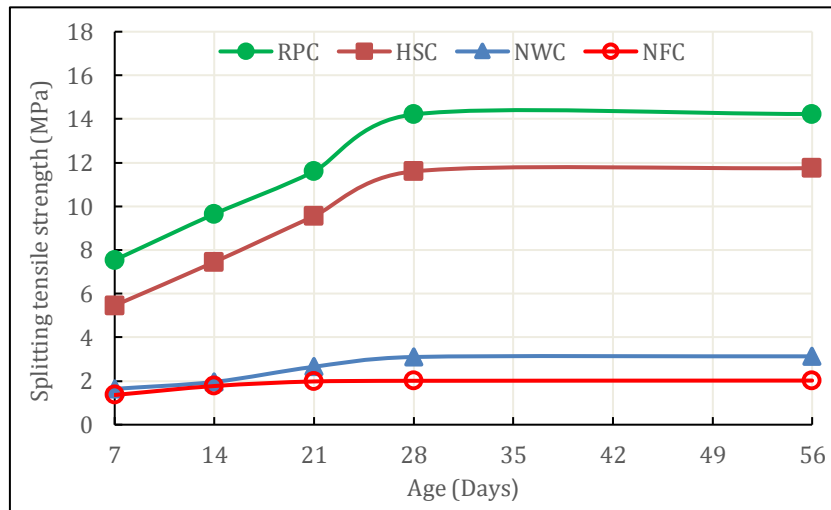

Fig. 2. Splitting tensile strength of different types of concrete.

Table 2. Splitting tensile strength as a function of time.

Type of concrete	Age (days)	Splitting tensile strength (MPa)	Change in splitting tensile strength with respect to reference mix (%)
M1 (NWC or OWC) Reference	7	1.6	0
	14	2.0	0
	21	2.7	0
	28	3.1	0
	56	3.3	0
M2 (HSC)	7	5.5	233
	14	7.5	280
	21	9.6	260
	28	11.6	274
	56	11.8	275
M3 (RPC)	7	7.5	360
	14	9.7	392
	21	11.6	338
	28	14.2	358
	56	14.2	355
M4 (NFC)	7	1.4	-17
	14	1.8	-10
	21	2.0	-25
	28	2.0	-35
	56	2.0	-36

3.3. Modulus of rupture (flexural strength)

The moduli of rupture values of different types of concrete are given in Fig. 3 and Table 3.

Based on the results listed in Table 3 and Fig. 3, the modulus of rupture strength at 28 days was 3.4 MPa for the reference concrete, NWC (OWC), while the same value was 11.9 MPa for the HSC, 16 for the RPC, and 2.6 MPa for the NFC.

3.4. Static modulus of elasticity

The static moduli of elasticities of different types of concrete are given in Fig. 4 and Table 4.

According to the test results, the values of the static modulus of elasticity at 28 days were 24.7 GPa for the NWC (OWC), 33.2 GPa for the HSC, 43.4 GPa for the RPC, and 20.9 GPa for the NFC.

3.5. Push-out tests

Push-out test specimen was produced according to the requirements of Eurocode 4 (EN 1994 - Eurocode 4, 1994). The shear connectors' properties were determined experimentally through simple push-out tests where two small slabs were linked to the flanges of an IPE 100 section by four studs on each side (Fig. 5). The slabs were bedded onto the lower part of a compression-testing machine, and the load was applied gradually to the top end of the steel section. A load-slip curve and then the stiffness of shear connectors were obtained.

The push-out segments were fabricated according to the dimensions of the studs as shown in Fig. 6. Then, they were cast and cured in water for 28 days. A hydraulic testing machine with a capacity of 2,000 kN was used to test the push-out segments at the Construction Laboratory of the Engineering Syndicate of Iraq Branch of Al-Anbar (see Fig. 7).

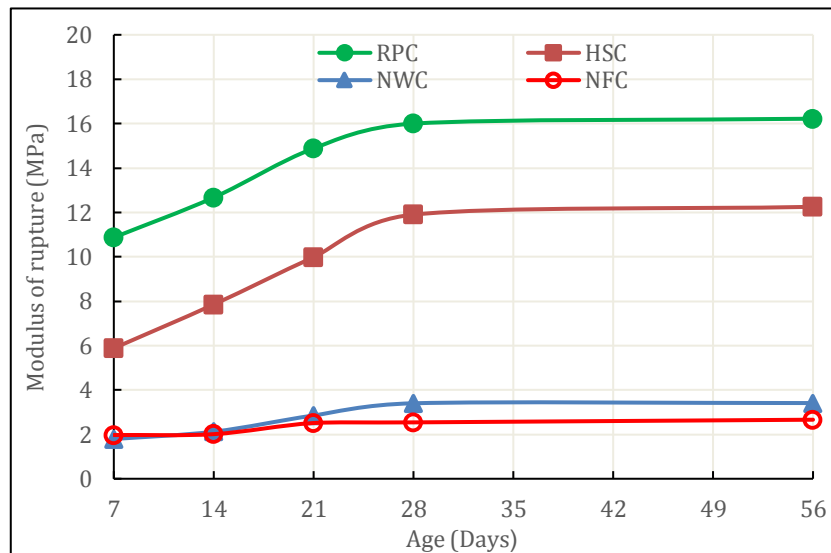

Fig. 3. Modulus of rupture of different types of concrete.

Table 3. Modulus of rupture as a function of time.

Type of concrete	Age (days)	Modulus of rupture (MPa)	Change in modulus of rupture with respect to reference mix (%)
M1 (NWC or OWC) Reference	7	1.8	0
	14	2.1	0
	21	2.9	0
	28	3.4	0
	56	3.4	0
M2 (HSC)	7	5.9	229
	14	7.9	270
	21	10.0	250
	28	11.9	250
	56	12.3	259
M3 (RPC)	7	10.9	507
	14	12.7	498
	21	14.9	422
	28	16.0	371
	56	16.2	376
M4 (NFC)	7	1.9	10
	14	2.0	-5
	21	2.5	-12
	28	2.6	-25
	56	2.7	-22

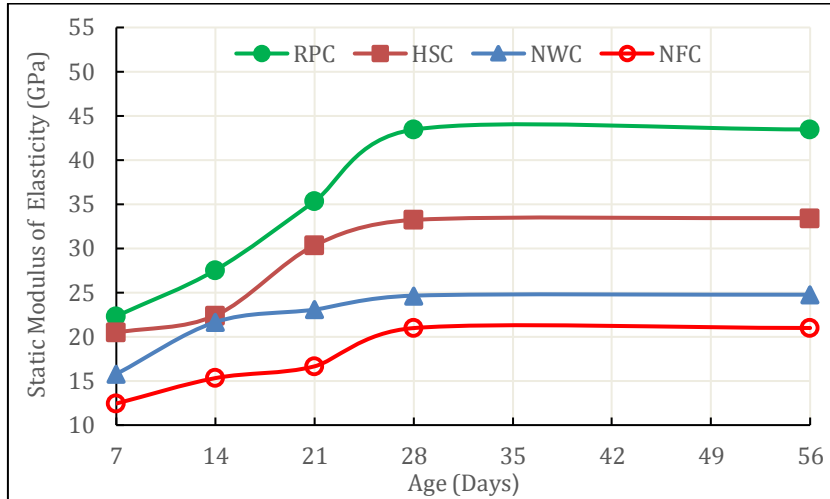

Fig. 4. Static modulus of elasticity of different types of concrete.

Table 4. Static modulus of elasticity for different types of concrete with time.

Type of concrete	Age (days)	Static modulus of elasticity (GPa)	Change in static modulus of elasticity with respect to reference mix (%)
M1 (NWC or OWC) Reference	7	15.8	0
	14	21.7	0
	21	23.1	0
	28	24.7	0
	56	24.8	0
M2 (HSC)	7	20.5	30
	14	22.4	4
	21	30.3	32
	28	33.2	35
	56	33.4	35
M3 (RPC)	7	22.3	42
	14	27.5	27
	21	35.3	53
	28	43.4	76
	56	43.5	76
M4 (NFC)	7	12.4	-21
	14	15.3	-29
	21	16.7	-28
	28	20.9	-15
	56	21.0	-15

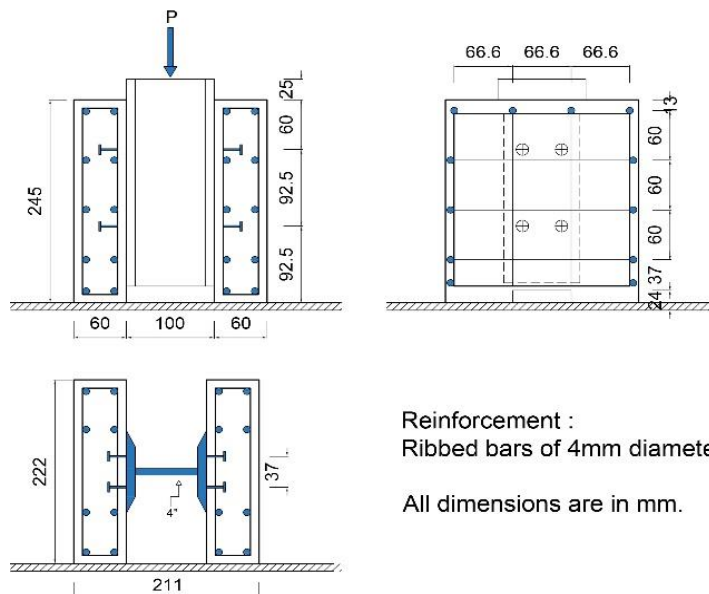

Fig. 5. Shear connectors for push-out tests.

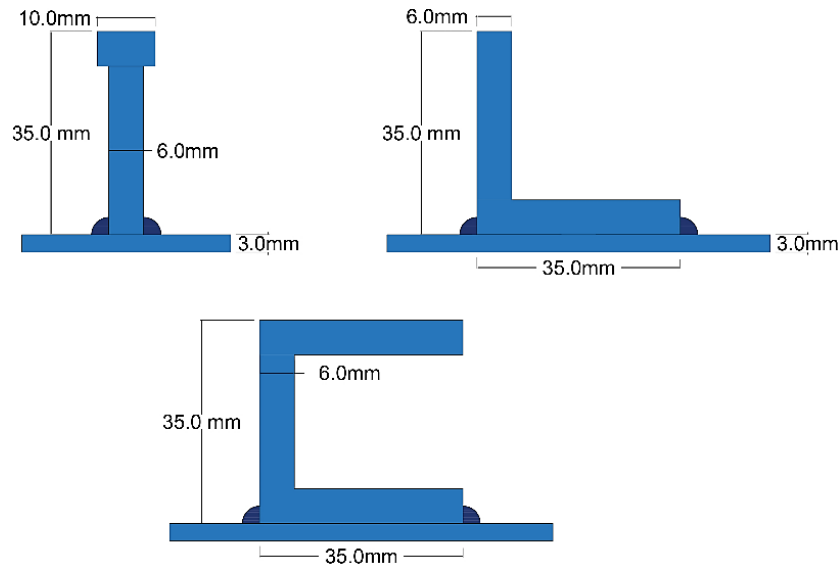

Fig. 6. Dimensions of shear connectors for push-out tests.



Fig. 7. Fabrication, casting, and testing of push-out specimens.

4. Test Results

The test results of push-out specimens are studied in three groups: (a) effect of shear stiffness, (b) effect of concrete type, and (c) effect of bond type. Because of the very poor test results that the no-fine aggregate concrete type (NFC) generated, the NFC is decided not to be further studied. Therefore, the behavior of shear studs will be studied for the following three different concrete types, NWC, HSC, and RPC.

4.1. Effect of shear stiffness

The variation in the shear stiffness of connectors is studied for each concrete type. The details of the test results are provided in the next subsections.

4.1.1. Normal (ordinary) weight concrete

The test results of different types of connectors in normal (ordinary) weight concrete are illustrated in Figs. 8, 9, and 10 based on the values given in Table 5.

In Table 5, a four-digit label is used for different specimens. The first letter in the label represents the type of concrete. The second letter is used to define the type of

different shear connectors. The third letter indicates the type of steel for the shear connectors, and the fourth letter is used to describe the type of connectors. For example, a label OHOW is used for the welded headed shear connector made of ordinary steel, which is embedded in an ordinary strength concrete.

According to the test results, the specimen OCHW resisted the largest shear force with a value of 876 kN, with a percentage of difference around 12% when compared to the shear value obtained from the specimen labeled OHHW. The lowest shear value was obtained in the specimen OLOE with a value of 248 kN.

4.1.2. High strength concrete

The test results for high strength concrete and different types of connectors are shown in Table 6 and Figs. 11, 12, and 13. The label notation was very similar to those that were used for the studs in normal weight concrete. The only difference was in the first digit, instead of normal strength concrete (N) a high strength concrete (H) was used.

According to the test results, the specimen HCHW had the largest shear capacity of 966 kN with a difference of approximately 1.3% when compared to the shear value of the specimen HHHW. The minimum shear capacity

was obtained in the specimen, HLOE, with a value of 411 kN. As illustrated in Fig. 13, the shear capacity of HCHE was slightly larger than that of HCOW. When the results of other C-shaped specimens with the same connection details were compared, a somewhat similar trend was also observed. In other words, the shear capacities of epoxy bonded high strength C-shaped steel connectors

were almost always very close to those of welded ordinary C-shaped steel connectors. However, in this particular case, as stated before, the shear capacity of HCHE was slightly larger. This increase was primarily attributed to the presence of high strength concrete and its interaction with the increased surface area of bonding around the shear connectors.

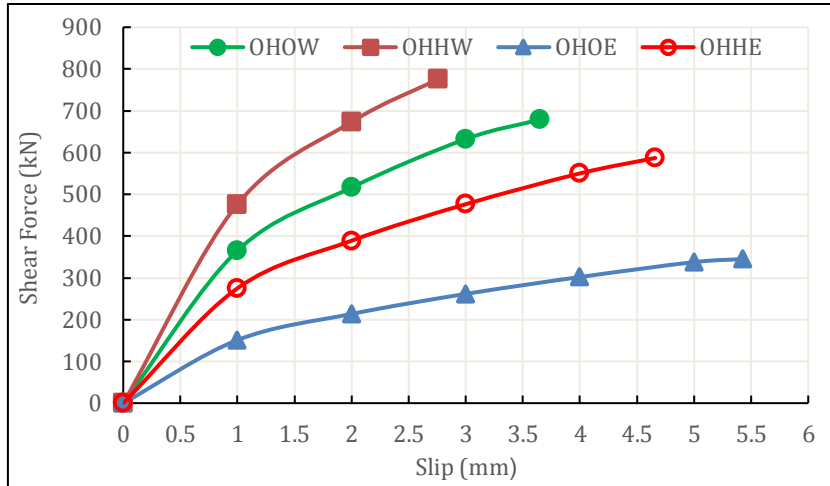

Fig. 8. Headed stud shear connectors with different types of steel properties and bonds in ordinary weight concrete.

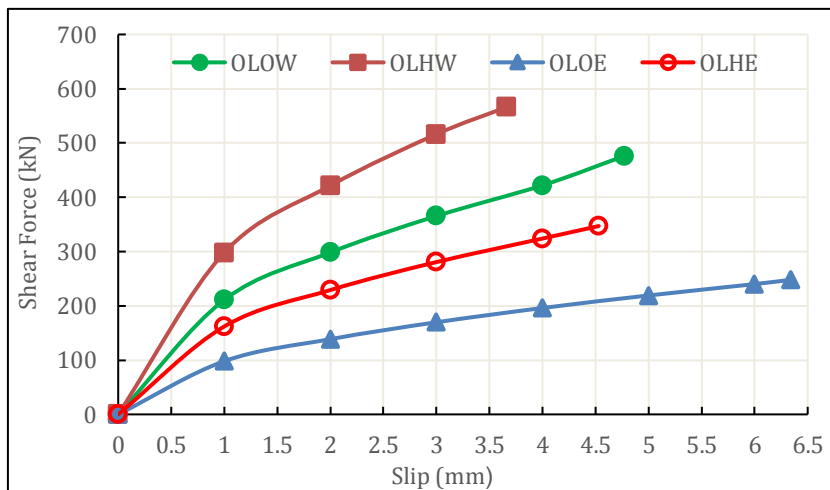

Fig. 9. L-shaped shear connectors with different types of steel properties and bonds in ordinary weight concrete.

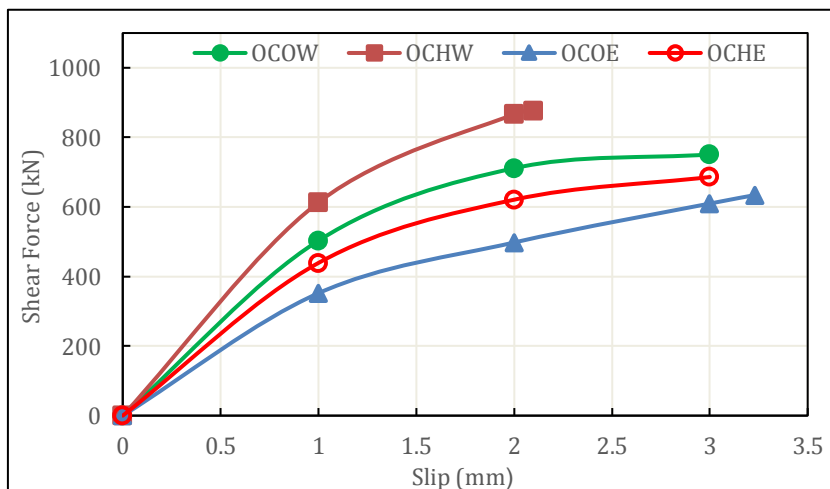

Fig. 10. C-shaped shear connectors with different types of steel properties and bonds in ordinary weight concrete.

Table 5. Test results of push-out test specimens in normal weight concrete.

Label	Type of shear connector	Type of steel strength	Type of bond	Ultimate shear force (kN)	Max. slip (mm)	Shear stiffness (kN/mm)	Difference (%)	Concrete crack width (mm)
OHOW	Headed stud (H)	Ordinary (O)	Welding (W)	679	3.65	93.0	0	0.10
OHHW	Headed stud (H)	High (H)	Welding (W)	776	2.76	140.7	0	0.04
OHOE	Headed stud (H)	Ordinary (O)	Epoxy (E)	345	5.43	31.8	0	0.32
OHHE	Headed stud (H)	High (H)	Epoxy (E)	587	4.66	63.0	0	0.19
OLOW	L- shaped (L)	Ordinary (O)	Welding (W)	476	4.77	49.9	-30	0.11
OLHW	L- shaped (L)	High (H)	Welding (W)	566	3.66	77.3	-27	0.09
OLOE	L- shaped (L)	Ordinary (O)	Epoxy (E)	248	6.34	19.6	-28	0.39
OLHE	L- shaped (L)	High (H)	Epoxy (E)	347	4.53	38.3	-41	0.22
OCOW	Channel (C)	Ordinary (O)	Welding (W)	751	2.99	125.6	11	0.08
OCHW	Channel (C)	High (H)	Welding (W)	876	2.09	209.6	13	0.03
OCOE	Channel (C)	Ordinary (O)	Epoxy (E)	634	3.23	98.1	84	0.11
OCHE	Channel (C)	High (H)	Epoxy (E)	686	3.01	114.0	17	0.09

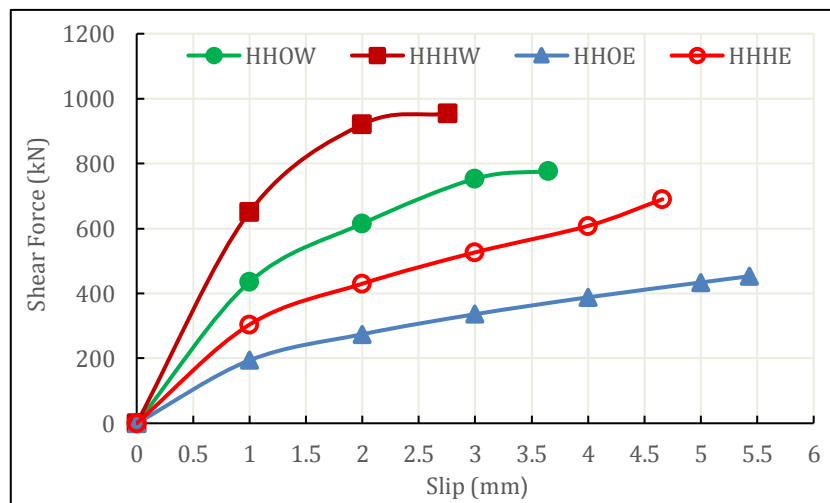

Fig. 11. Headed stud shear connector with different types of steel properties and bonds in high strength concrete.

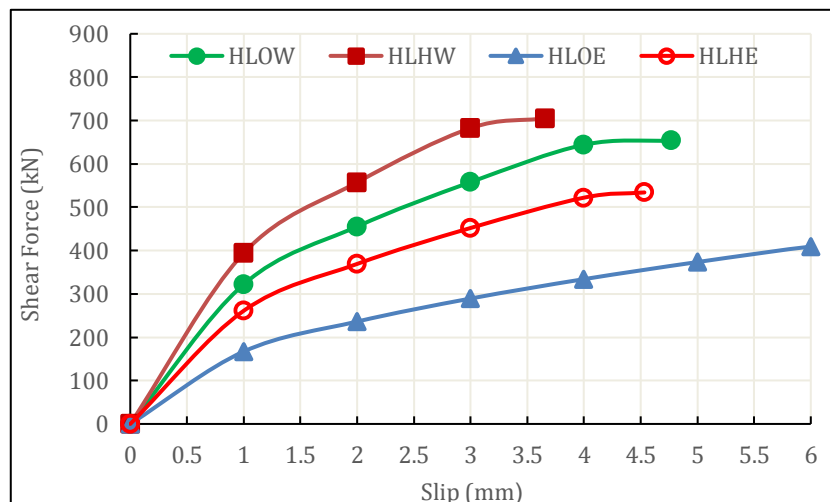

Fig. 12. L- shaped stud shear connector with different types of steel properties and bonds in high strength concrete.

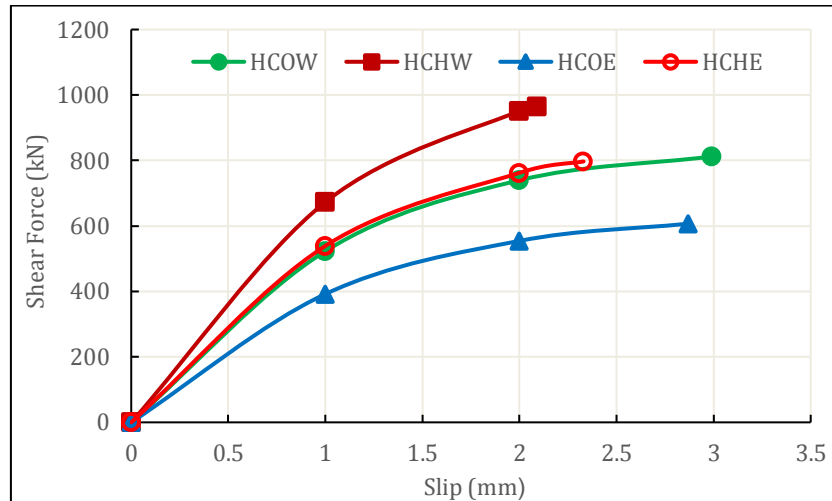

Fig. 13. C- shaped stud shear connector with different types of steel properties and bonds in high strength concrete.

Table 6. Test results of push-out test specimens in high strength concrete.

Label	Type of shear connector	Type of steel strength	Type of bond	Ultimate shear force (kN)	Max. slip (mm)	Shear stiffness (kN/mm)	Difference (%)	Concrete crack width (mm)
HHOW	Headed stud (H)	Ordinary (O)	Welding (W)	777	3.65	106.4	0	0.07
HHHW	Headed stud (H)	High (H)	Welding (W)	954	2.76	172.8	0	0.03
HHOE	Headed stud (H)	Ordinary (O)	Epoxy (E)	453	5.43	41.7	0	0.21
HHHE	Headed stud (H)	High (H)	Epoxy (E)	690	4.66	74.0	0	0.12
HLOW	L- shaped (L)	Ordinary (O)	Welding (W)	654	4.77	68.6	-16	0.09
HLHW	L- shaped (L)	High (H)	Welding (W)	705	3.66	96.3	-26	0.07
HLOE	L- shaped (L)	Ordinary (O)	Epoxy (E)	411	6.34	32.4	-9	0.31
HLHE	L- shaped (L)	High (H)	Epoxy (E)	534	4.33	61.7	-23	0.21
HCOW	Channel (C)	Ordinary (O)	Welding (W)	812	2.99	135.8	5	0.07
HCHW	Channel (C)	High (H)	Welding (W)	966	2.09	231.1	1	0.03
HCOE	Channel (C)	Ordinary (O)	Epoxy (E)	607	2.87	105.7	34	0.09
HCHE	Channel (C)	High (H)	Epoxy (E)	797	2.33	171.0	16	0.08

4.1.3. Reactive powder concrete

The test results of reactive powder concrete are listed in Table 7, and displayed in Figs. 14, 15, and 16. The label notation of the specimens in reactive powder concrete is very similar to those in normal and high strength concretes. The only difference is the first letter, R, which, in this case, represents the reactive powder concrete.

Based on the test results, the specimen RCHW generated the largest shear force value of 1,215 kN, with a difference of 10% compared to the shear value of the specimen RHHW. The minimum shear capacity was obtained in the specimen RLOE with a value of 601 kN.

The test results indicated that the specimens with L-shaped shear connectors were more susceptible to concrete related failures because of a very high stress concentration within a smaller area of concrete, which

caused maximum concrete crack width. In these specimens, the failure was caused by the crushing of the concrete contained below the L-shaped connectors. In general, the welding bond was better and gave higher shear force values with less slip values.

4.2. Effect of concrete type

The variation in the shear stiffness of connectors is studied for each concrete type. The details of the test results are provided in the next subsections.

The load-slip curves of different concrete types are plotted in Figs. 17, 18, and 19. In Fig. 17, it appears that the specimen with the headed stud shear connectors which exhibited the least shear force resistance was the OHOE, and the strongest one with the maximum shear force resistance was the RHHW. Based on the

test results, it was observed that the increase in the shear force value of RHHW with the same characteristics of shear connectors and bonds, was around 16% and 42% with respect to the shear force resistance values of HHHW and OHHW, respectively (see Fig. 17).

As illustrated in Fig. 17, among the other headed stud shear connectors, the load-slip curve of the RHHW,

which displayed a fracture type of failure, came to an abrupt end at the shear force value of 1,103 kN corresponding to a slip value of 2.06 mm. However, the specimens which displayed concrete failures such as the OHOE specimen exhibited a gradual drop in the load-slip curve extending to a 5.43 mm of slip value at a shear force value of 345 kN.

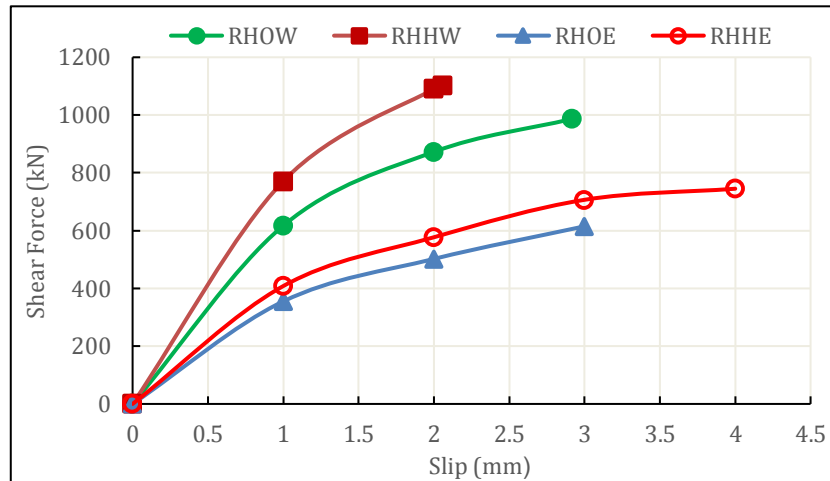

Fig. 14. Headed stud shear connector with different types of steel properties and bonds for reactive powder concrete.

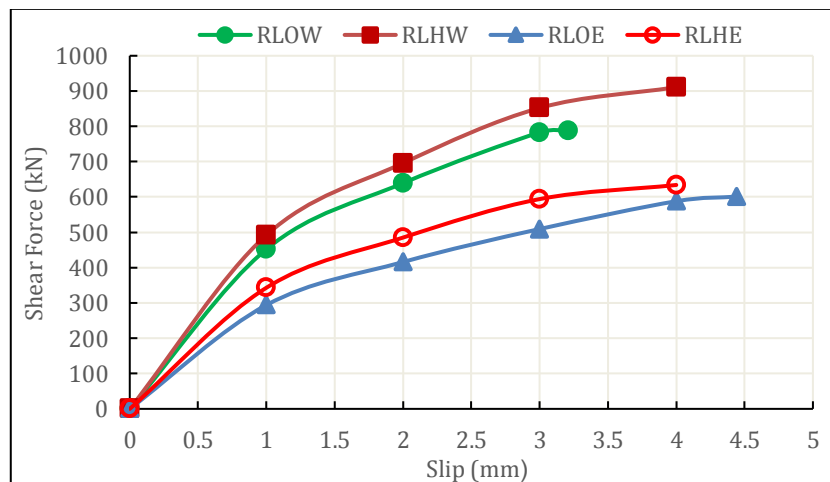

Fig. 15. L- shaped shear connector with different types of steel properties and bonds for reactive powder concrete.

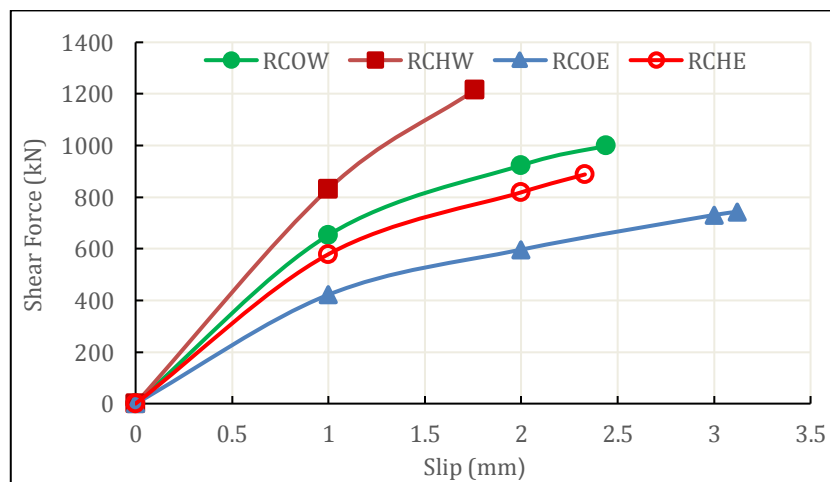

Fig. 16. C- shaped shear connector with different types of steel properties and bonds for reactive powder concrete.

Table 7. Test results for push-out test in reactive powder concrete.

Label	Type of shear connector	Type of steel strength	Type of bond	Ultimate shear force (kN)	Max. slip (mm)	Shear stiffness (kN/mm)	Difference (%)	Concrete crack width (mm)
RHOW	Headed stud (H)	Ordinary (O)	Welding (W)	987	2.92	169.0	0	0.05
RHHW	Headed stud (H)	High (H)	Welding (W)	1103	2.06	267.7	0	0.02
RHOE	Headed stud (H)	Ordinary (O)	Epoxy (E)	665	3.11	106.9	0	0.18
RHHE	Headed stud (H)	High (H)	Epoxy (E)	745	4.00	93.1	0	0.10
RLOW	L- shaped (L)	Ordinary (O)	Welding (W)	788	3.21	122.7	-20	0.08
RLHW	L- shaped (L)	High (H)	Welding (W)	911	3.99	114.2	-17	0.05
RLOE	L- shaped (L)	Ordinary (O)	Epoxy (E)	601	4.44	67.7	-10	0.21
RLHE	L- shaped (L)	High (H)	Epoxy (E)	634	4.00	79.3	-15	0.11
RCOW	Channel (C)	Ordinary (O)	Welding (W)	999	2.44	204.7	1	0.05
RCHW	Channel (C)	High (H)	Welding (W)	1215	1.76	345.2	10	0.02
RCOE	Channel (C)	Ordinary (O)	Epoxy (E)	743	3.12	119.1	12	0.06
RCHE	Channel (C)	High (H)	Epoxy (E)	888	2.33	190.6	19	0.04

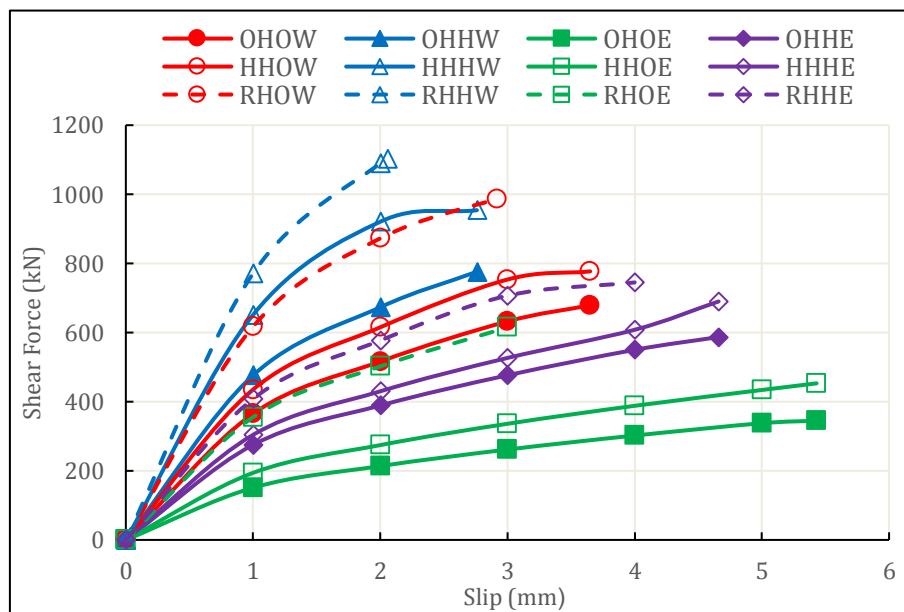

Fig. 17. Load slip curves of headed stud shear connectors with different types of concrete and bonds.

In Fig. 18, it appears that the weaker specimen with the minimum shear force resistance was the OLOE, where epoxy was used for bonding. The strongest specimen with the maximum shear force was the RLHW, where the welding was used for bonding purposes. Based on the test results, it was observed that the increase in the shear force value for the RLHW was around 29% and 61% when its shear force resistance was compared to the HLHW and the OLHW, respectively. As shown in Fig. 18, the load-slip curve of the RLHW with a fracture type of failure came to an end at a much shorter slip value (approximately 4 mm at a shear force value of 911 kN) while those related with the concrete failure

types such as the OLOE exhibited a gradual drop at a much longer slip value (approximately 6.34 mm at a shear force value of 248 kN).

Based on the results plotted in Fig. 19, it appears that the weaker specimens with the minimum shear force values was the OCOE and HCOE, while the strongest one with the maximum shear force value was the RCHW. The increase in the shear force value of the RCHW was around 26% and 39% with respect to the shear force values of the HCHW and the OCHW, respectively.

Once again, the load-slip curve of the RCHW, where fracture type of failure occurred, came to an abrupt end at the slip value of 1.76 mm under 1,215 kN of shear

force. However, the specimens with concrete types of failures, such as the OCOE and HCOE exhibited a longer slip curve reaching maximum slip values of 3.23 mm and 2.87 mm at the shear force values of 634 kN and 607 kN, respectively.

Based on the overall test results extracted from the three previous figures (Figs. 17, 18 and 19), the reactive powder concrete, RPC, generated the maximum shear forces due to the increase in the compressive strength of concrete as compared to the OPC and HPC.

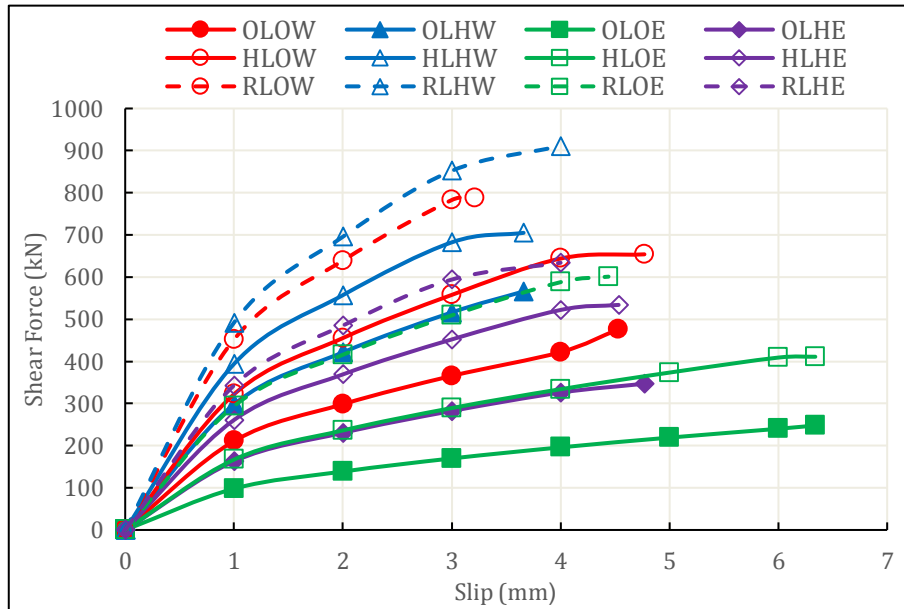

Fig. 18. Load slip curves of L-shaped shear connectors with different types of concrete and bonds.

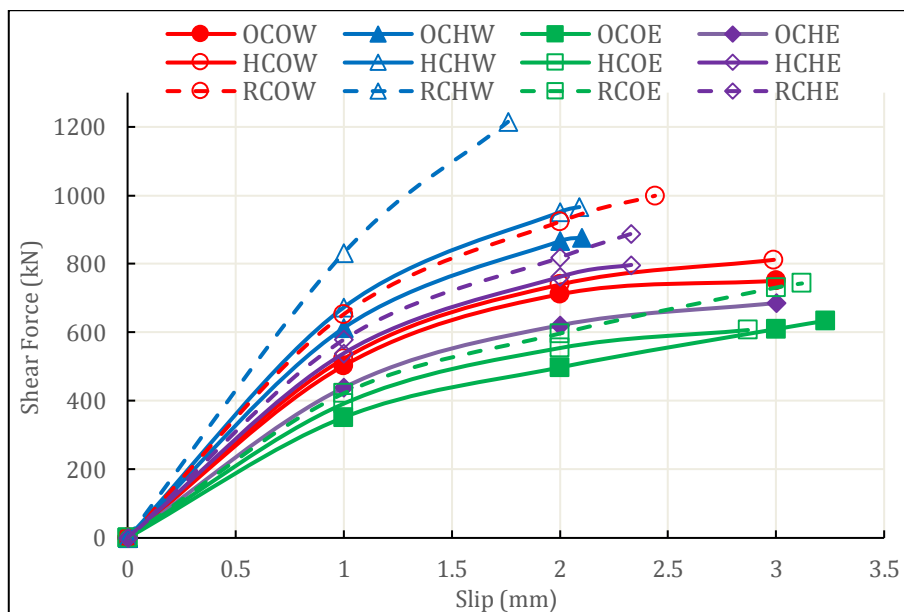

Fig. 19. Load slip curve of C-shaped shear connectors with different types of concrete and bonds.

4.3. Effect of bond type

The variation in the shear stiffness of connectors is studied for each concrete type. The details of the test results are provided in the next subsections.

The load-slip curves of shear studs in different types of concrete with varying bond types are presented in Figs. 20, 21, and 22. Based on the data illustrated in Fig. 20, it appears that the specimen with the minimum shear force capacity was the OLOE and the one with the

maximum shear capacity was the OCHW. According to the test results, it was observed that the increase in the shear force capacity of the OCHW was around 17%, 38%, and 28% when the results were compared to those of the OCOW, OCOE, OCHE, respectively.

Based on the results plotted in Fig. 21, it appears that the specimen that generated the minimum shear force was the HLOE while the one that generated the maximum shear force was the HCHW. Based on the test results, it was observed that the increase in the shear force

value for specimen HCHW was around 19%, 59%, and 21% when the results were compared to those obtained from the HCOW, HCOE, HCHE, respectively.

Fig. 22 illustrates the load slip curves of shear studs in reactive powder concrete type (RPC) with different types of bonds. Based on the data plotted in Fig. 22, it appears that the specimen that generated the largest shear force was the RCHW and the one that generated the smallest shear force was the RLOE. It was observed that the increase in the shear force value of the RCHW was around 22%, 64%, and 37% when the results were compared to those of the RCOW, RCOE, RCHE, respectively.

Based on the overall results that are extracted from the three previous figures (Figs. 20, 21, and 22), it can be concluded that the C-shaped shear connectors resisted higher shear forces due to the increase in the surface contact area associated with the concrete. The load-slip curves of shear studs in the OCHW, HCHW, and RCHW exhibited fracture types of failures, and the testing came to an abrupt end whereas those related to the concrete failure, the OLOE, HLOE, and RLOE, exhibited a gradual drop with larger slip values.

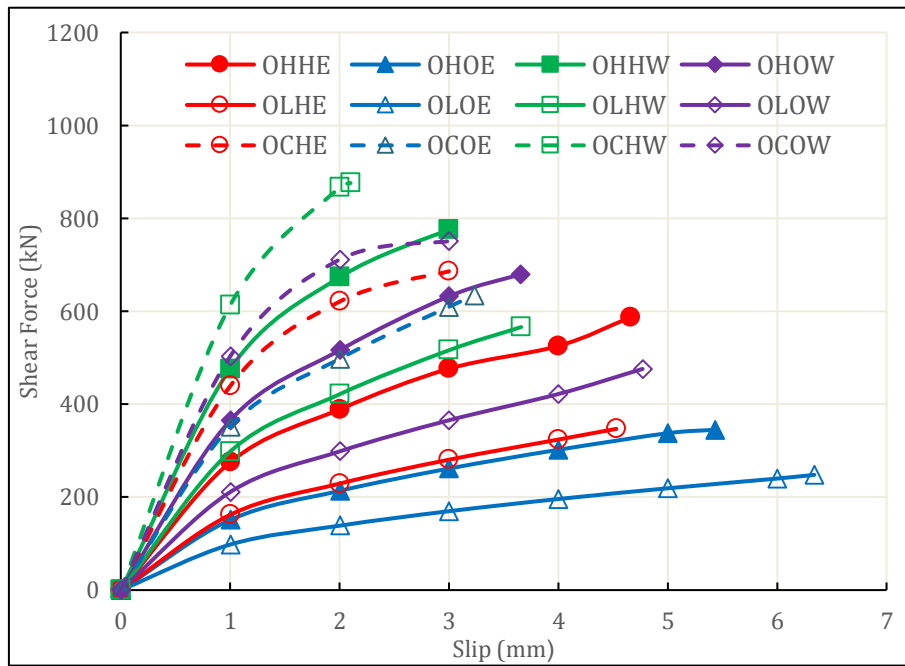

Fig. 20. Load slip curve of shear studs in an ordinary concrete type with different types of bonds.

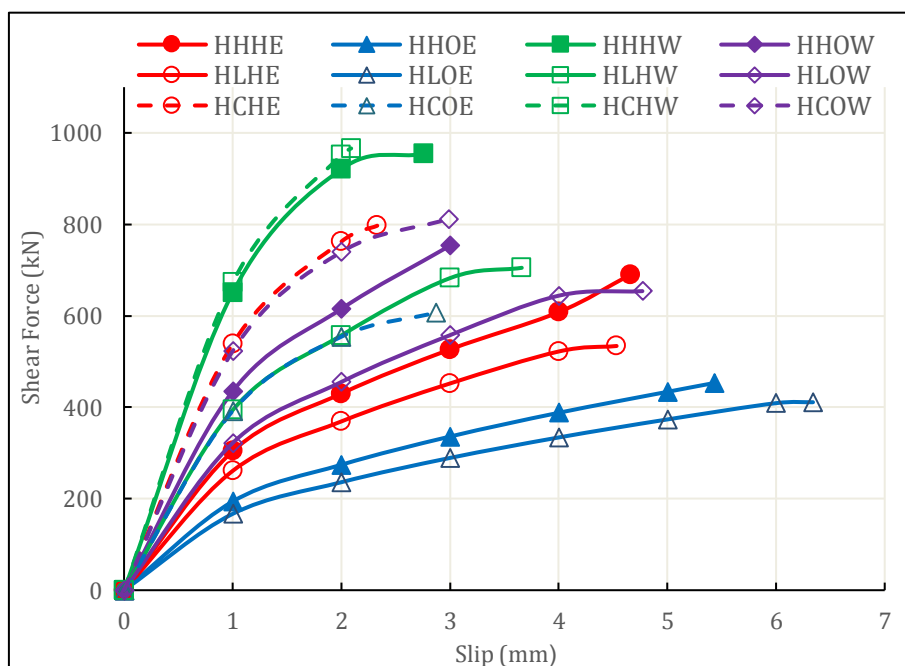

Fig. 21. Load slip curve of shear studs in high strength concrete with different types of bonds.

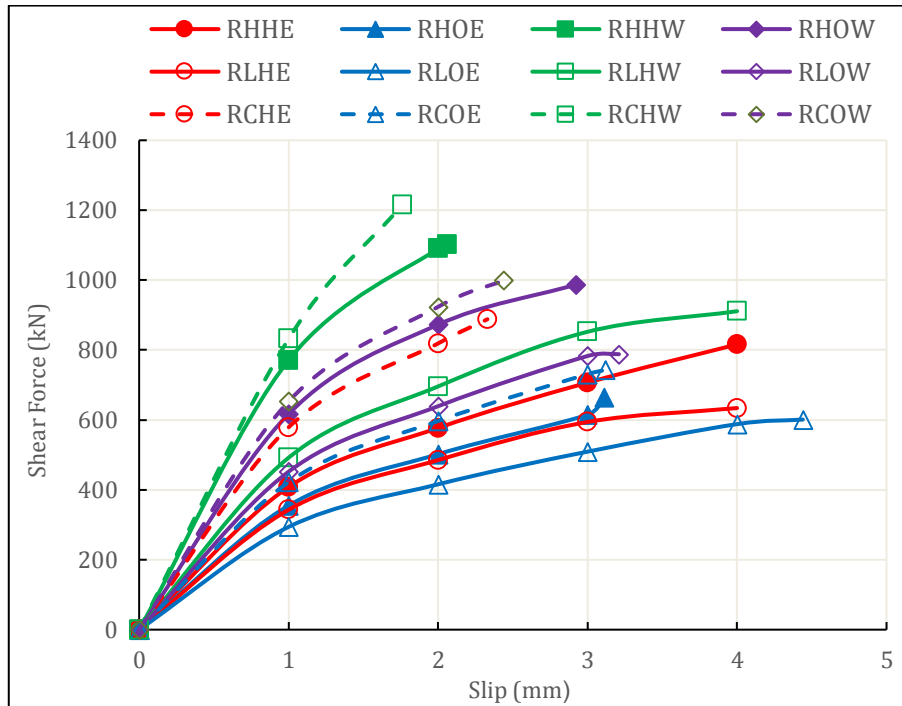

Fig. 22. Load slip curve of shear studs in reactive powder concrete with different types of bonds.

5. Conclusions

The test results are investigated in two separate groups. In the first group, the mechanical properties of different types of concrete were examined. In the second group, the test data from the push-out specimens were studied. The findings of this study can be applied to real world scenarios. Although a great deal of further research must be completed in this field, this study attempted to fill the gap by exploring the structural behaviours of various shaped shear connectors with welded and epoxy bonded connections in different types of concrete.

Mechanical Properties of Concrete:

- The compressive strength of concrete increases with age. The RPC and HSC generated the best compressive strength values by an increase of 348% and 218%, respectively, when their results were compared to that of normal concrete at 28 days.
- The splitting tensile and flexural strength values of concrete increased when the RPC and the HSC were used. The RPC and HSC generated higher strength values compared to that of normal concrete. The increase in the splitting tensile strength of the RPC and the HSC at 28 days with respect to that of normal concrete was 358% and 274%, respectively, while in the flexural strength case, the increase was 371% and 250%, respectively. For the NFC, the maximum splitting tensile and flexural strengths were 2.0 MPa and 2.7 MPa.
- The values of Static Modulus of Elasticity increased in the RPC and HSC. The RPC and HSC generated 76% and 35% more modulus of elasticity compared to that of normal concrete at 28 days.

Push-out Specimens:

In this group, the maximum shear forces were compared to those from the headed stud case since the headed stud shear connectors were commonly used in practice.

- OCHW generated the best shear force value of 876 kN with a percentage of difference of 87% when the result was compared to the force of OHHW.
- HCHW produced the best shear force value of 966 kN with a percentage of difference of 1.3% when the result was compared to the shear force value generated in HHHW.
- RCHW resisted the largest shear force value of 1215 kN, with a percentage of difference of 10% when the result was compared to that of RHHW.

Based on the test results, the reactive powder concrete generated the largest shear force values for all shear stud types. Below, a more in-depth comparison is presented:

- The increase in the shear force value of headed studs welded in RHHW was around 16% and 42% when the result was compared to those of HHHW and OHHW, respectively. If epoxy is used instead of welding, then the increase in the same specimens with epoxy became 8% and 27%, respectively.
- The increase in the shear force value of L-shaped studs welded in RLHW was around 29% and 61% when the results were compared to those of HLHW and OLHW, respectively. If epoxy is used, then the increase in the same specimens became 19% and 83%, respectively.
- The increase in the shear force value of C-shaped studs welded in RCHW was around 25% and 39% when the results were compared to those of HCHW

and OCHW, respectively. If epoxy is used, then the increase in these specimens with epoxy was 11% and 30%, respectively.

The shear resistance of welded and epoxy bonded shear studs were also compared to each other. Below list includes the detailed comparisons among the specimens:

- The increase in the shear force value of OCHW was around 28%, 17% and 38% when the result was compared to those of OCHE, OCOW, and OCOE, respectively.
- The increase in shear force value for HCHW was around 21%, 19% and 59% when the shear force was compared to those of HCHE, HCOW, and HCOE, respectively.
- The increase in the shear force value of RCHW was around 37%, 22% and 64% when the shear force value was compared to those generated in RCHE, RCOW, and RCOE, respectively.

Acknowledgements

We would like to acknowledge the assistance of Osama Mahmood Hussein during the testing phase of this study.

REFERENCES

- Adekola AO (1968). Partial interaction between elastically connected elements of a composite beam. *International Journal of Solids and Structures*, 4(11), 1125-1135.
- Al-Shafi'i NTH (2013). Shear Behavior of Reactive Powder Concrete T-beams. *Ph.D. thesis*, Department of Civil Engineering, University of Al-Mustansiriya, Baghdad, Iraq.
- Aziz KI (2005). Behavior of Multi-layer Composite Beams with Partial Interaction. *Ph.D. thesis*, Department of Civil Engineering, University of Technology, Baghdad, Iraq.
- Bae BI, Chung JH, Choi HK, Jung HS, Choi CS (2018). Experimental study on the cyclic behavior of steel fiber reinforced high strength concrete columns and evaluation of shear strength. *Engineering Structures*, 157, 250-267.
- Di J, Zou Y, Zhou X, Qin F, Peng X (2018). Push-out test of large perfbond connectors in steel-concrete joints of hybrid bridges. *Journal of Constructional Steel Research*, 150, 415-429.
- EN 1994 - Eurocode 4 (1994). Design of composite steel and concrete structures. European Committee for Standardization, Brussels, Belgium.
- Fallah S, Nematzadeh M (2017). Mechanical properties and durability of high-strength concrete containing macro-polymeric and polypropylene fibers with nano-silica and silica fume. *Construction and Building Materials*, 132, 170-187.
- He S, Fang Z, Mosallam AS (2017). Push-out tests for perfbond strip connectors with UHPC grout in the joints of steel-concrete hybrid bridge girders. *Engineering Structures*, 135, 177-190.
- Hirama C, Ishikawa T, Hisagi A (2017). Special Issue: Proceedings of Eurosteel 2017. In: *Jönnsso J, editor. Shear strength of headed stud push-out tests: comprehensive literature review focusing on slab type, failure mode, and large-diameter headed stud*. Wiley Online Library, 2013-2022.
- Hmeed YM (2014). Behavior of reinforced concrete I-beams containing reactive powder concrete. *Ph.D. thesis*, Department of Civil Engineering, University of Al-Mustansiriya, Baghdad, Iraq.
- Ismael MA (2013). Flexural Behavior of Reactive Powder Concrete Tee Beams. *Ph.D. Dissertation*, Department of Civil Engineering, University of Al-Mustansiriya, Baghdad, Iraq.
- Newmark, NM, Siess, CP, Viest IM (1951). Tests and analysis of composite beams with incomplete interaction. *Proceedings of the Society for Experimental Stress Analysis*, 9(1), 75-92.
- Wandscher VF, Marchionatti AME, Otani A, Bergoli CD, Cesar PF, Valandro LF (2018). Effects of bonding area size, surface treatment and specimen configuration on the push out test for assessing bonding and stress distribution to Y-TZP. *International Journal of Adhesion and Adhesives*, 85, 315-321.
- Wardi AHW (2019). Behavior of High Strength Shear Connectors Embedded in Concrete. *M.Sc. thesis*, Department of Civil Engineering, Atılım University, Ankara, Turkey.