



Research Article

Experimental examination of strength and behavior of masonry brick walls strengthened with expanded steel plates

Ezatullah Ahmadzai ^a , Zeynep Yaman ^{a,*} , Alper Cumhuri ^b 

^a Department of Civil Engineering, Sakarya University, 54187 Sakarya, Turkey

^b Department of Civil Engineering, Yalova University, 77200 Yalova, Turkey

ABSTRACT

As primary load-bearing members of masonry buildings, the strength and behavior of masonry brick walls are the most important factors affecting the structural performance for the loads the building is exposed to during its life span. The current paper therefore experimentally examines a structural strengthening method to improve the performance and behavior of masonry brick walls. Masonry walls were strengthened with expanded steel plates of different thicknesses attached to the walls using different numbers of bolts. Five wall specimens were examined under a diagonal static compression test. For strengthening, expanded steel plates were anchored to both sides of un-plastered walls using bolts and were then plastered. The thickness of the steel plates and the number of bolts were examined as experimental variables. The results showed that the strengthened wall specimens using expanded steel plates of different thicknesses and different numbers of bolts increased an average of 45-94% ultimate strength at 245mm displacement, the ductility of all strengthened specimens increased by 114%-180% and an average increment of 280-480% higher energy dissipation capacities compared to the reference specimen. The result shows that strengthening masonry brick walls provides 2 to 3 times higher energy dissipation capacity for the energy generated by seismic effects compared to the reference specimen. The research then indicated the expanded plate thickness in strengthening walls has a direct relation with load-bearing capacity of brick masonry walls. An increase of 33% and 100% in plate thickness resulted to increase in load bearing capacity by 2% and 11.5%, respectively. It has also been observed that specimens did not experience a sudden drop in load carrying capacity. They maintained their stability until the end of the tests and changed their stiffness and ductility.

ARTICLE INFO

Article history:

Received 5 July 2022

Revised 1 August 2022

Accepted 22 August 2022

Keywords:

Masonry brick walls

Strengthening

Expanded steel plates

Diagonal compression test

1. Introduction

Brick masonry structure is one of the preferred and typical method of construction due to several advantages including rapid production, low cost, high heat, and sound isolation (Mezrea et al. 2021; Özyurt et al. 2020; Hejazi et al. 2015; Budak et al. 2004). Brick masonry buildings are very common in Turkey; however, these structures need to be strengthened due to their heterogeneity and mechanical properties. Since brick, the main material of the building structure, does not

have sufficient ductility for tensile and shear stresses (İstegün et al. 2018), it exhibits a low energy dissipation capacity (Koç 2016; Korkmaz 2014; Çırak 2011). Low ductility and energy dissipation capacity of brick masonry buildings can cause sudden damage to the walls (Cheng et al. 2020). Therefore, strengthening interventions are required for a great portion of the existing brick masonry buildings to improve structural strength and behavior (Marques et al. 2022; Orulkaya 2019).

As load-bearing members, brick masonry walls are forced to make plastic deformation and displacement in

multi directions with altered amounts under the different types of loads (forces) that the structure is exposed to. The difference in displacements depends on the stiffness of the masonry brick walls (Bahçekapılı 2003). Strength of a masonry building depends on both the bond between brick and mortar (Karaton and Çanakçı 2021) as well as the strength of the masonry material (Güvenir 2019; Erköseoğlu 2014). Although brick masonry walls have sufficient strength under vertical loads (gravity loads, live loads, etc.), they don't have sufficient strength for lateral loads (earthquake loads, etc.). To increase lateral strength and load-bearing capacity, new strengthening techniques should be introduced. The applicability of such a new strengthening technique depends on minimizing the environmental and economic effects of the method (Mezrea et al. 2021).

Many previous studies presented strengthening practices for buildings and structural members (Maali et al. 2019; Aydin et al. 2020; Ağcakoca 2020). In addition, some studies focused on wall strengthening applications. In the past reports, different methods were used for strengthening brick infill walls and brick masonry walls using plaster (Arslan et al. 2020; Sevil et al. 2010), concrete (Kaya 2013; Baran et al. 2014; Ateş 2013; Kalkan 2008), epoxy resin and fiber-reinforced polymer strips (Abdulsalam et al. 2021; Kalali and Kabir 2012), textile (Koutas et al. 2014), and some other materials (Rebelo et al. 2021; Corradi et al. 2020; Hamdy et al. 2018; Chen et al. 2012; Ozsayin et al. 2011; Mosallam 2007; Ehsani et al. 1999). In these studies, strengthened specimens exhibited higher ductility, load-carrying capacities, energy dissipation capacities, stiffness, and seismic resistance performances. Furthermore, brick infill walls were also strengthened using steel profiles (Özbek et al. 2012), steel plates (Papanicolaou et al. 2011), expanded steel plates (Leeanansaksiri et al. 2018; Aykaç et al. 2017; Cumhuriyet 2016), perforated steel plates (Özbek et al. 2019; Özbek 2015; Seydanlıoğlu 2013; Babayani 2012), steel mesh (Tekeli et al. 2014; Özdemir and Eren 2011), steel strips (Özmen 2018) and the impact of strengthening on the behavior of the load-bearing system were examined (Johansson, et al. 2014; Sevil et al. 2010). The results of these studies showed that the load-bearing capacity, energy absorption capacity, diagonal compression capacity, stiffness, and ductility of the reinforced specimens increased.

This research aims to fill the gap in the literature by presenting experimental evidence for strengthening brick masonry walls with expanded steel plates, which is

a practical and environmental friendly strengthening method. Since the use of masonry members is a common construction method in Turkey, the strengthening method examined in this study is important as an accessible technique to users in Turkey.

This study presents a rapid and practical technique for strengthening the currently existing and future masonry building walls to improve lateral rigidity and strength of the structure, prevent out-of-plane behaviors of the walls exposed to earthquake loading, and ensure life and structural safety. The study was carried out on 5 test specimens (samples); one was normal wall (reference) and four were strengthened wall specimens. In the experimental study, diagonal static incremental loading was applied to the specimens. For strengthening, expanded steel plates were installed and fixed on both sides of the un-plastered walls using bolt connection. The effect of expanded steel plate thickness and the number of bolts on the wall load-bearing capacity were then examined and analyzed under loading.

2. Material and Method

To produce test specimens, expanded steel plates manufactured in Turkey and vertical-hole blocks which are widely used in masonry building construction in Turkey were used in the lab experiments. Standard construction workmanship was performed in the production of the specimens. As load-bearing members in masonry buildings, strengthening of the walls made of vertical-hole blocks with dimensions 135×190×290 mm was examined. A total of 5 sample walls, each with dimensions of 1000×1000 mm (one was the reference and four were strengthened) were tested (Table 1).

The specific weight (γ) of the bricks used in the study was 700 kg/m³. To determine the characteristics of the bricks, 30 bricks were separately tested to find the brick properties (Fig. 1). The compressive strength of the bricks was examined according to the TS EN 772-1+A1 standard (Table 2).

The thicknesses of the expanded steel plates were 1.5, 2.0, and 3.0 mm with an average yield strength (σ_y) of 280 MPa. The steel plates were processed in a factory using cutting and expanding procedures, and expanded steel plates with perforations having dimensions of 54×26 mm were obtained. No welding or mounting procedures were applied on expanded steel plates (Fig. 2(a)).

Table 1. Specimen properties.

Specimen	Plaster thickness (mm)	Plate thickness (mm)	Bolt interval (mm)	Number of bolts
Reference	25	-	-	-
MBW 1.5-150	25	1.5	150	49
MBW 2.0-150	25	2.0	150	49
MBW 3.0-150	25	3.0	150	49
MBW 3.0-400	25	3.0	400	9

MBW = Masonry Brick Wall

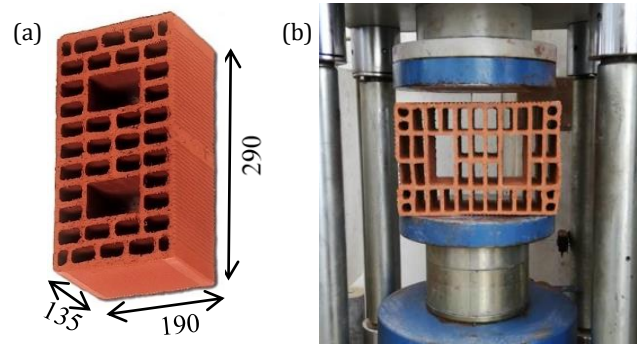

Fig. 1. (a) Vertical-hole brick; (b) Compressive strength tests.

Table 2. Compressive strength tests results of the vertical-hole brick.

		Mean breaking load (kN)	Compressive strength (MPa)
Parallel to holes	Mean	169.6	3.3
	SD	51.4	1.0
Long axis perpendicular to holes	Mean	124.5	3.3
	SD	24.5	0.7
Short axis perpendicular to holes	Mean	30.5	1.3
	SD	11.7	0.5

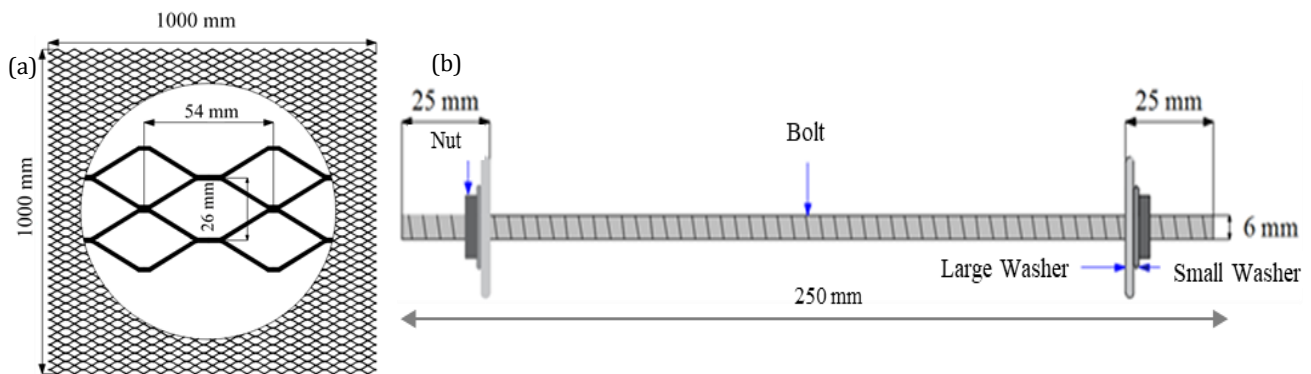

Fig. 2. Materials used in wall strengthening: (a) Expanded steel plate; (b) Geometries of the bolt, washer, and nut.

To attach expanded steel plates to the walls, bolts, washers, and nuts were used (Fig. 2(b)). The bolts were produced by cutting 250 mm-long pieces from 6-mm fully threaded 1-m long S235 steel bars.

Holes were drilled at the determined points on the wall specimens with a drill, expanded steel plates were then placed on the walls, and fixed using bolts, washers, and nuts (Figs. 3 and 4).



Fig. 3. (continued)



Fig. 3. Preparation of the experimental setup.

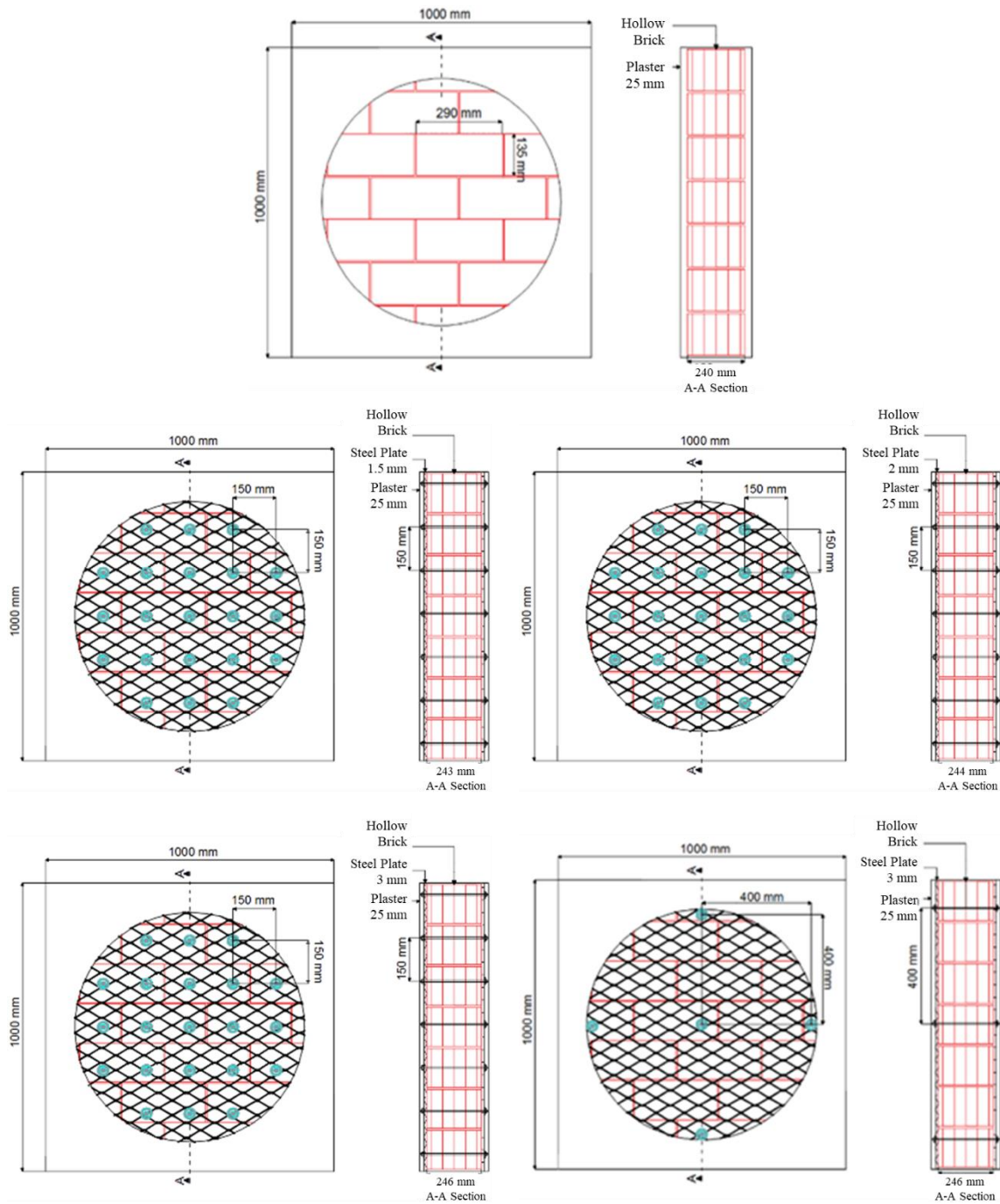

Fig. 4. Design of the test specimens.

The bolts were tightened with 3 Nm tightening torque considering the post-tensioning stress. The same mix composition was used for preparing plaster and mortar. Wall mortar and plaster mixes were prepared using the water-sand-lime-cement ratio given in Table 3.

In the experimental examinations, diagonal compression loading was applied. According to the definition of the diagonal compression test in the ASTM E519, 1/8 of the side span of the side edges to the diagonal loading point are fastened by loading shoes and other parts of the edges are set free during the loading. However, in the real case, depending on earthquake-induced displacements, the contact area of the brick masonry walls with the lateral and vertical peripheral ties can be higher than specified in ASTM E519 (Cumhur et al. 2016). Therefore, in this study, square steel frames with (internal) dimensions of 1000×1000 mm used by Cumhur et al. (2016) to transfer the diagonal load to infill wall specimens (Fig. 5). Steel frames were produced by hinged connected profiles. Hinges ensured transferring the entire applied diagonal load to the test specimens and that the steel frame does not resist to loading.

Table 3. Weight ratio of the materials used in plaster and mortars.

Material	Water	Lime	Sand	Cement
%	10	10	60	20

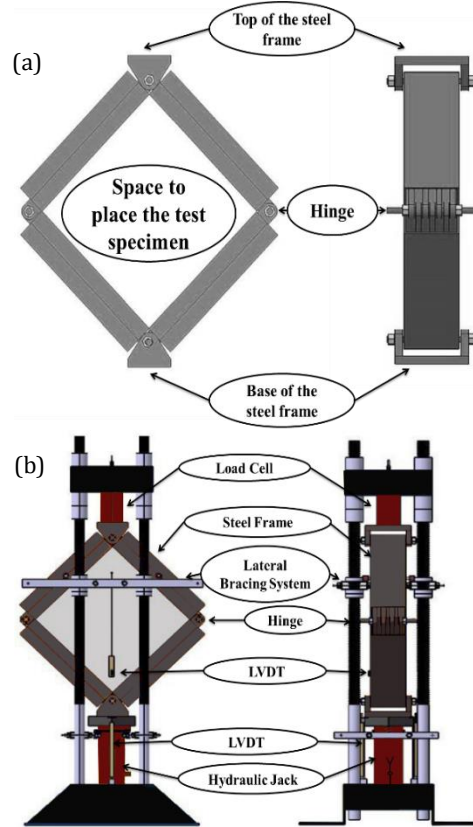

Fig. 5. Experimental study: (a) Steel rigid frame with hinged from four edges; (b) Loading test setup.

Out-of-plane behavior of the frame was prevented using stiffness elements (lateral support system). Thus, the load was transferred to the test specimen diagonally from the center of the frame. The load was applied to the test specimen using single action 1000 kN hydraulic jack

(Fig. 6) through a speed-controlled loading system depending on the displacement. The loading speeds varied according to the displacements as follows: 5% up to 10 mm displacement, 25% up to 10-35 mm displacement, and 50% beyond 35 mm displacement.

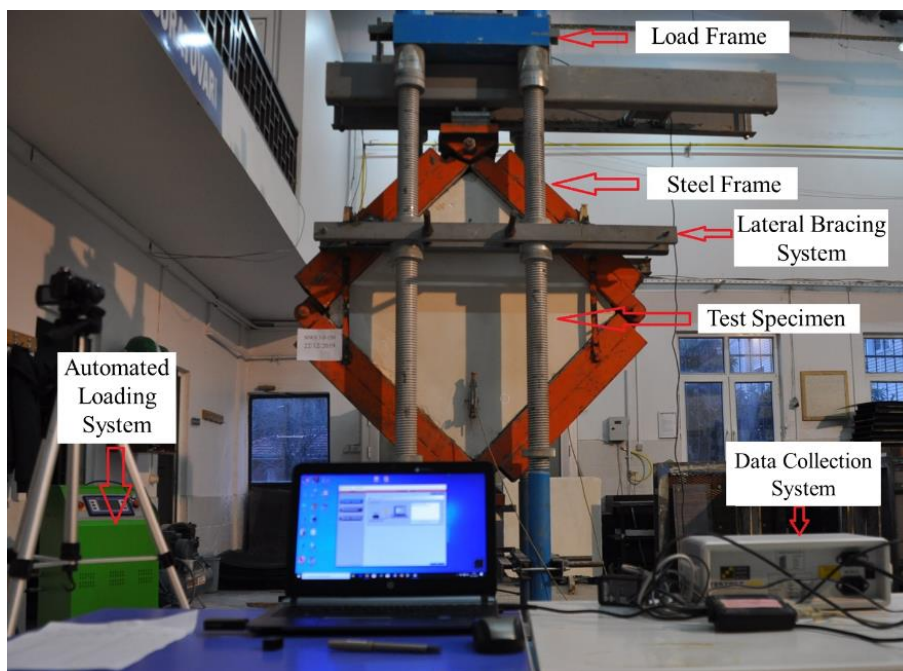

Fig. 6. Test setup.

To measure the displacements in the test specimens, 4 LVDT (Linear Variable Differential Transformer) were used. Two 400 mm LVDT were attached to the base of the rigid frame to measure shortenings of the specimens

along the loading axis. Two 50 mm LVDT were placed on the front and back of the test specimens to measure shortenings of the specimens along the loading axis and elongation perpendicular to the loading axis (Fig. 7).

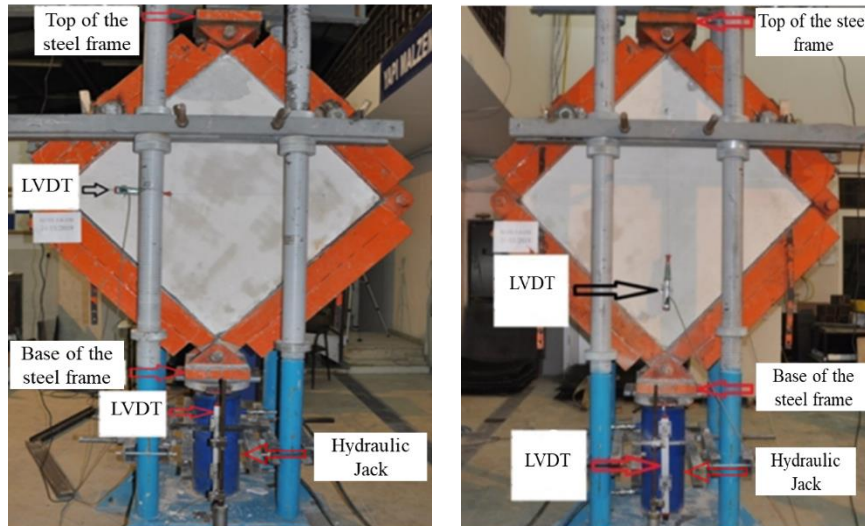

Fig. 7. Placement of LVDTs.

3. Analysis of the Experimental Results

Only plastering layer was applied to both sides of the reference specimen and no strengthening material was used. During the tests, the reference specimen exhibited very brittle behavior and had abrupt load drops. Since abrupt load drops occurred and the reference specimen showed non-ductile behavior, a very limited amount of displacement was observed. After the test started, fine hairline cracks were observed on the both front and back plaster surfaces at a load of 60 kN and a displacement of 31 mm. The first crack was observed 20 cm from the right side of the middle diagonal of the specimen at a load of 85 kN and a displacement of 36 mm. The width of the first crack was measured to be approximately 3 mm. Towards the end of the experiment, the cracks continued to grow and blisters became more evident. The maximum load-carrying capacity of the reference specimen was measured 99.87 kN and the displacement was recorded 25.9 mm. The test was terminated after a displacement of 90 mm since the specimen no longer carry any loads. The contact surface of the reference specimen was measured as about 70% (70 cm).

For the specimen MBW 1.5-150, obvious blisters progressing towards the frame was observed on both front and back surfaces of the specimen around the hinges at a load of 125 kN and a displacement of 91 mm. The maximum load-carrying capacity of the specimen was noted 154.65 kN and the displacement at this load was counted 65.5 mm. The contact surface of the specimen was measured as 65% (65 cm) on average.

For the specimen MBW 2.0-150, obvious lateral blistering was observed on both front and back surfaces of the specimen around the lower hinge due to compression at a load of 141 kN and a displacement of 64 mm. Plus, some blistering progressing towards the frame

around the hop hinge was also observed. The maximum load-carrying capacity of the specimen was found to be 160.2 kN and the displacement at this load was calculated as 34 mm. The contact surface of the specimen MBW 2.0-150 was measured as 58% (58 cm) on average.

For the specimen MBW 3.0-150, hairline cracks were observed on the middle region of the plaster both on front and back surfaces of the specimen at a load of 147 kN and a displacement of 28 mm. Furthermore, a significant plaster crack in the loading direction was observed on the back surface of the specimen near the lower hinge and blistering around the top hinge due to compression. On the other hand, at a load of 135 kN and a displacement of 122 mm, lateral cracks and about 30 cm above the lower hinge blistering on both front and back surfaces and plaster blisters progressing towards the frame were observed due to compression. The maximum load-carrying capacity of the specimen MBW 3.0-150 was found to be 160.35 kN and the displacement at this load was calculated as 36.76 mm. The contact surfaces of the specimen MBW 3.0-150 on four corners were measured as 48% (48 cm) on average.

Finally, for the specimen MBW 3.0-400, hairline plaster cracks in the middle region of the front surface were observed at a load of 145 kN and a displacement of 28 mm. Plus, plaster blistering and falling off occurred on the front surface of the specimen near the top and lower hinges due to compression. The maximum load-carrying capacity of the specimen was calculated as 147.28 kN and the displacement at this load was found to be 23.59 mm. The contact surface of the specimen MBW 3.0-400 was measured as 60% (60 cm) on average.

The undamaged state of the specimens, the damage condition after the test and the load-displacement curves are shown in Fig. 8. Test results were summarized in Table 4.

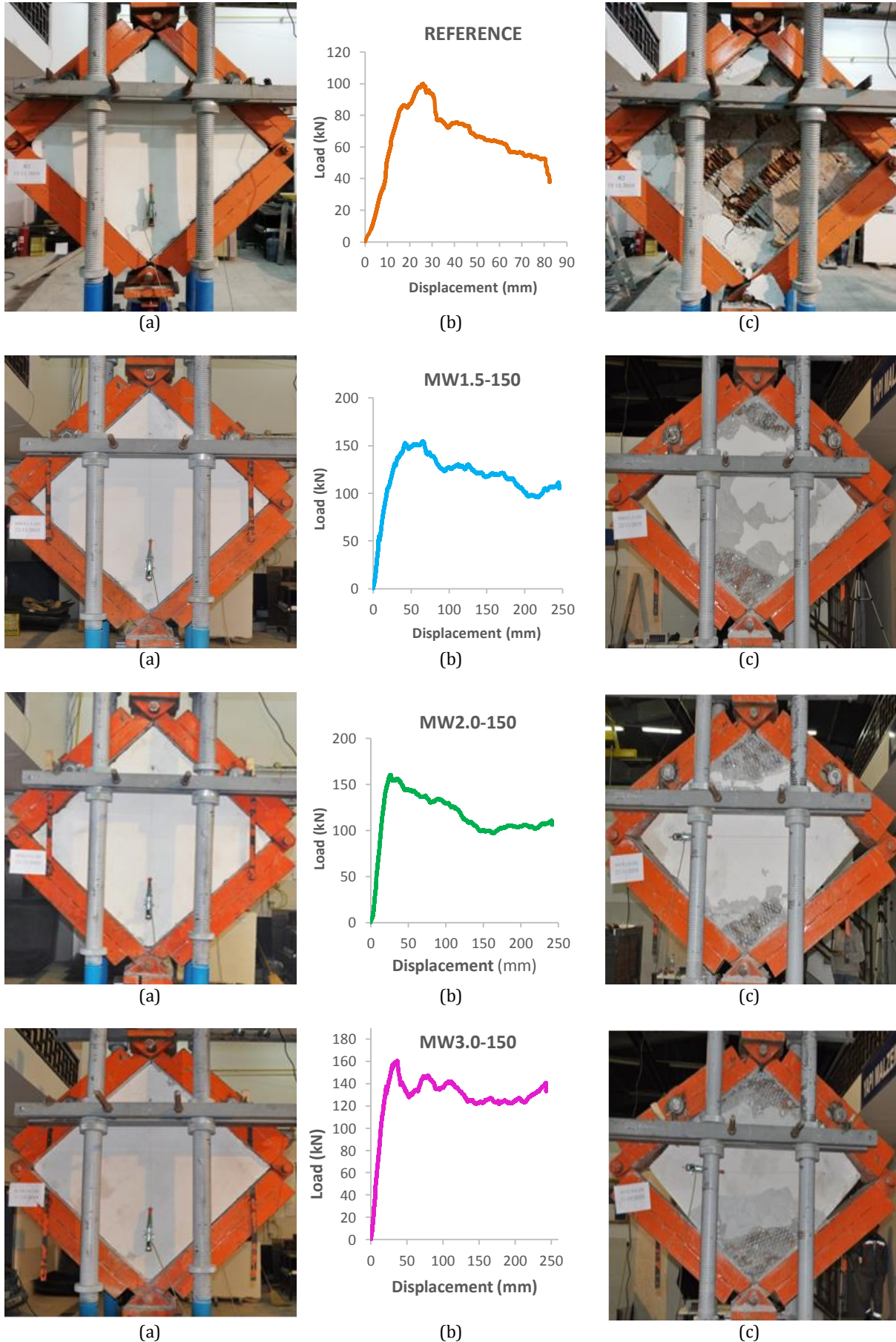

Fig. 8. (continued)

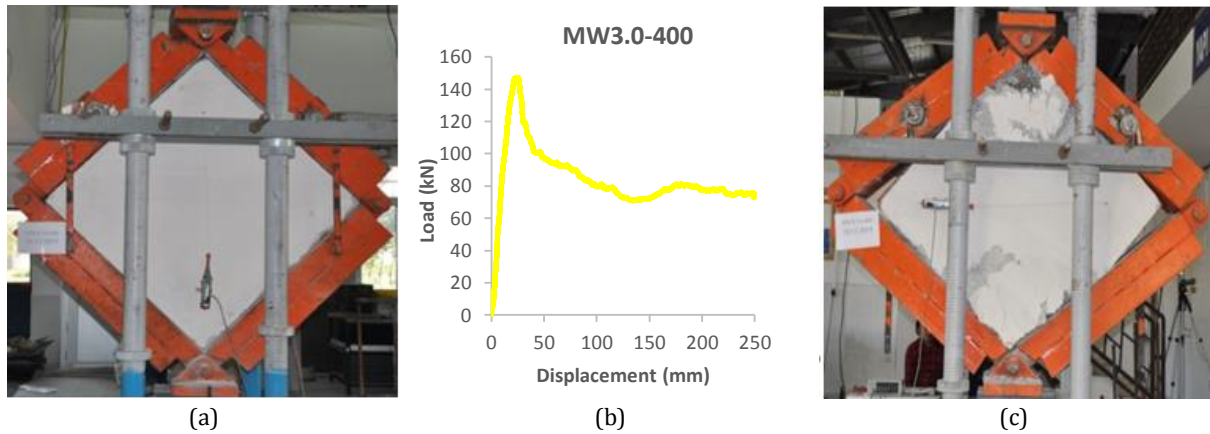

Fig. 8. Test members: (a) Before the test; (b) Load-displacement curve; (c) After the test.

Table 4. Maximum load-carrying capacities and contact areas of the specimens.

Specimen	Max load (kN)	Displacement at maximum load (mm)	Contact area at maximum load (%)	Maximum displacement (mm)	Average contact area (%)
Reference	99.87	25.91	48.75	82.38	70
MBW 1.5-150	154.65	65.51	39.50	245.25	65
MBW 2.0-150	160.20	34.02	29.50	241.70	58
MBW 3.0-150	160.35	36.76	30.50	243.13	48
MBW 3.0-400	147.28	23.59	18.00	249.18	60

The carrying capacity, stiffness, and ductility capacities of the specimens were calculated according to Fig. 9 using the test results. In the curve, (P_y) is load-carrying capacity at yield, (δ_y) is displacement at yield, (P_{max}) is maximum load-carrying capacity, (δ_0) is displacement at

maximum load, (δ_f) is maximum displacement, (P_f) is load-carrying capacity at maximum displacement, (δ_i) is displacement at the beginning of the stiffness curve, (P_t) is load-carrying capacity, and (δ_t) is the displacement corresponding to P_t .

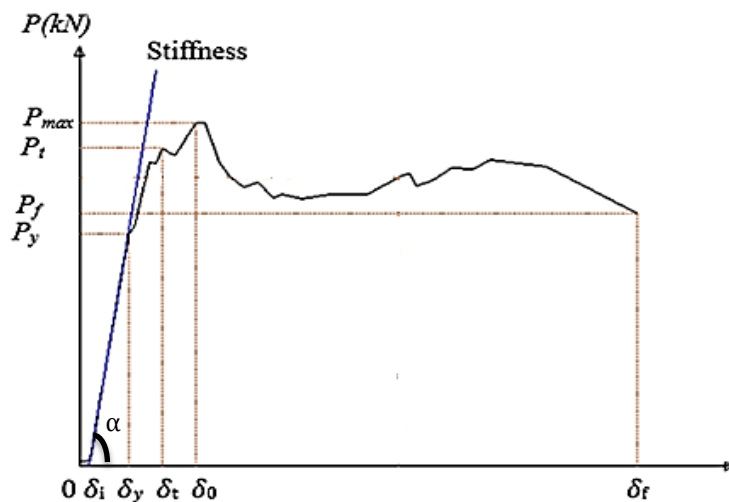

Fig. 9. A sample load-displacement curve used to calculate the ductility of the specimens.

Load-carrying capacity at yield (P_y), maximum load-carrying capacity (P_{max}), load-carrying capacity at maximum displacement (P_f), and relative increase in the ultimate strength values according to the reference specimen are given in Table 5. Ultimate strength values were

calculated using the average of (P_{max}) and (P_f) values (Cumhur 2016).

The initial stiffness of the specimens was calculated using the ratio of yield load (P_y) to displacement at yield (δ_y) (Table 6).

Table 5. Ultimate strength values and relative increase according to the reference specimen.

Specimen	P_y (kN)	P_{max} (kN)	P_f (kN)	Ult. strength at 245mm displacement (kN)	Relative increase in ult. Strength (%)
Reference	86	99.87	51.3	75.59	-
MBW 1.5-150	105	154.65	108.18	131.42	73.86
MBW 2.0-150	140	160.20	108.15	134.18	77.52
MBW 3.0-150	147	160.35	132.88	146.62	93.97
MBW 3.0-400	140	147.28	72.68	109.98	45.51

Table 6. Stiffness and relative increase in stiffness according to the reference specimen.

Specimen	P_y (kN)	δy (δ_y^-) (mm)	Stiffness (kN/mm)	Relative increase in stiffness (%)
Reference	86	17(15)	5.73	-
MBW 1.5-150	105	18(16)	6.56	14.46
MBW 2.0-150	140	23(21)	6.67	16.28
MBW 3.0-150	147	22(20)	7.35	28.20
MBW 3.0-400	140	21(20)	7.00	22.09

Ductility of the specimens were calculated from the ratio of the maximum displacement to the displacement at yield. The maximum displacement value (δ_f^-) was calculated using the Eq. (1), displacement at yield (δ_y^-) using the Eq. (2), and ductility was calculated by Eq. (3).

$$\delta_f^- = \delta_f - \delta_i \quad (1)$$

$$\delta_y^- = \delta_y - \delta_i \quad (2)$$

$$\text{Ductility} = \delta_f^- / \delta_y^- \quad (3)$$

The area under the load-displacement curve gives the energy dissipation capacity of the specimen. The ductility and energy dissipation capacities of the specimens are given in Table 7.

The load-displacement curves of all specimens are shown in Fig. 10(a). Load-carrying capacities, stiffness, ductility, and energy dissipation capacities of the specimens are comparatively given in Figs. 10(b-c-d-e).

Table 7. Ductility and relative increase in ductility according to the reference specimen

Specimen	δ_i (mm)	δ_f (mm)	δ_y (mm)	δ_f^- (mm)	δ_y^- (mm)	Ductility	Ductility ratio (%)	Energy dissipation capacity (kJ)	Relative increase in energy dissipation capacity (%)
Reference	2	82.38	17	80.38	15	5.36	-	5.3	-
MBW 1.5-150	2	245.25	18	243.25	16	15.20	183.71	28.3	433.96
MBW 2.0-150	2	241.70	23	239.70	20	11.99	123.66	29.5	456.60
MBW 3.0-150	2	243.13	22	241.13	21	11.48	114.28	30.6	477.36
MBW 3.0-400	1	249.18	21	247.18	20	12.36	130.64	20.2	281.13

4. Conclusions

This study presents a strengthening method for both existing and future masonry brick walls through examination of 5 test specimens under diagonal static. Expanded steel plates were used for strengthening; thickness and bolt interval were examined as variables. In order to ensure the economic production of test specimens, no special materials were used. The materials used in the production of the specimens were easily available and common materials. Moreover, the examined strengthening method was also an easily applicable technique for a wide range of scenarios.

Based on the observations made during the tests and

the analysis of the curves obtained by the experimental data, the following key findings were obtained:

- The un-strengthened reference specimen reached to collapse state immediately after reaching elastic load-carrying capacity due to the stress cracks that occurred under diagonal loading. This was expected behavior for a wall built from masonry brick which is a brittle material. For strengthened specimens, we observed that a great portion of the tensile stresses was covered by expanded steel plates and the walls exhibit composite behavior until the yield of the bolts.
- Ultimate strength at 245mm displacement of all strengthened walls increased in the range of 45%-94% compared to the reference specimen.

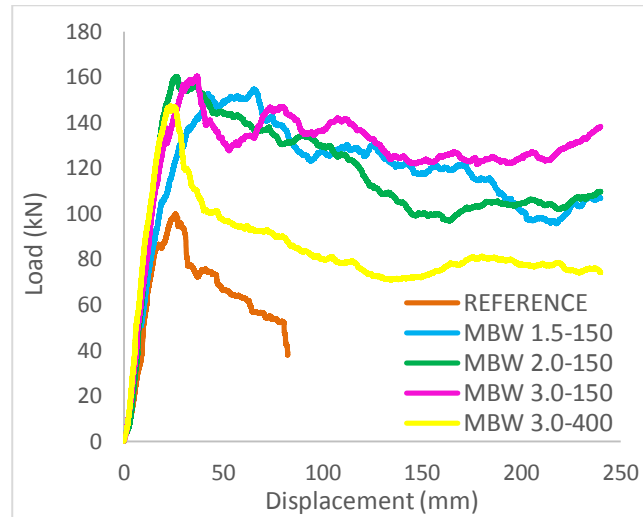

(a)

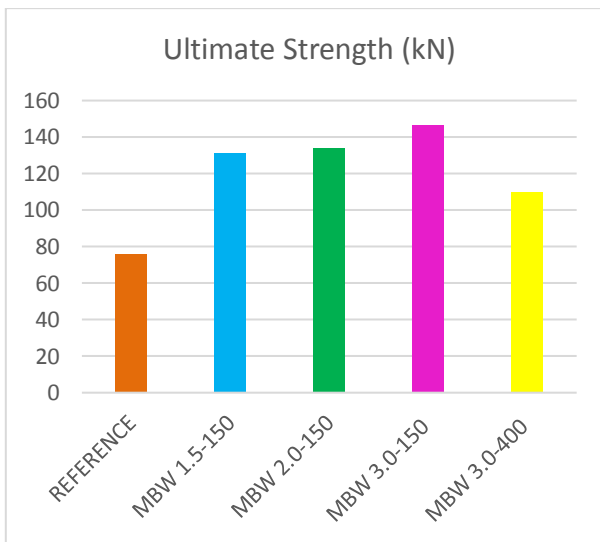

(b)

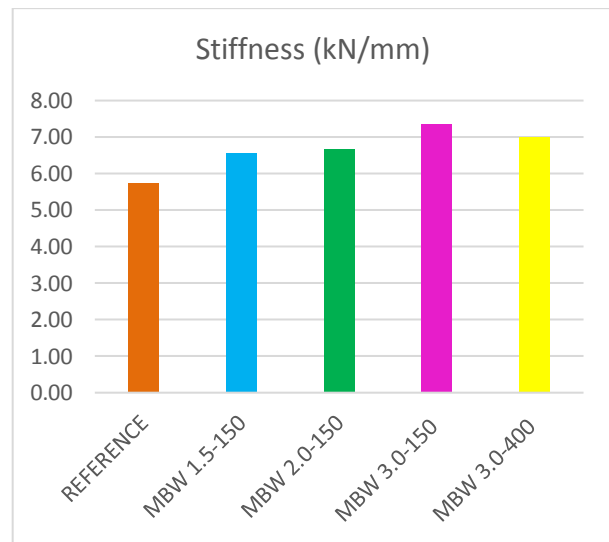

(c)

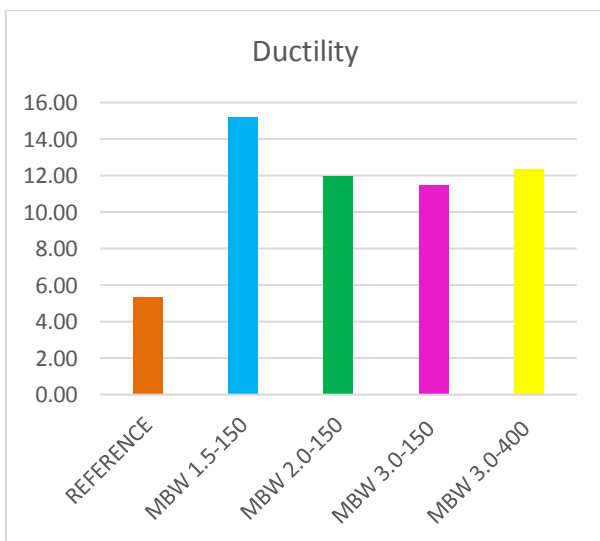

(d)

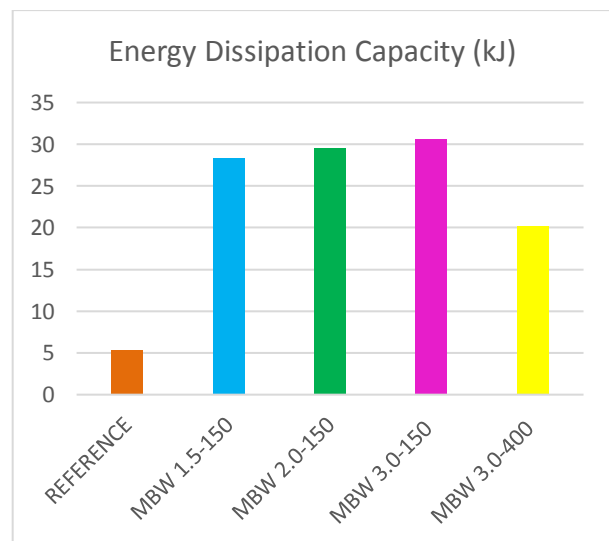

(e)

Fig. 10. Comparative presentation of the specimens' load-carrying capacities, stiffness, ductility, and energy dissipation capacities.

- All strengthened walls exhibited great plastic deformation after reaching the elastic load-carrying capacities and ductile behavior. The ductility of all strengthened specimens increased by 114-180% according to the reference. These results show that strengthening provides 2 to 3 times higher energy dissipation capacity for the energy generated by seismic effects like earthquakes compared to the reference specimen.
- As the plate thickness increased for the same bolt interval, no significant decrease in the load-carrying capacities was observed. In addition, the specimens maintained their integrity until the end of the tests. Accordingly, load-carrying capacities, energy dissipation capacities, ductility, and stiffness of the specimens strengthened with expanded steel plates significantly increased. As the plate thickness increased by 33% and 100% from 1.5 mm, load-carrying capacities were increased by 2% and 11.5%, respectively. It can be therefore argued that increasing plate thickness results in higher strength in masonry brick walls. However, since this increase is not too much, strengthening with 1.5 mm-thick steel plates was found to be the optimum thickness that provides sufficient strengthening performance. For the same plate thickness, even the steel plates fixed to the walls with high bolt intervals (MBW 3.0-400), the ductility increased by 130% compared to the reference specimen.
- Energy dissipation capacities of the strengthened specimens increased by 280-477% according to the reference specimen. The comparison of the specimens with the same plate thickness but different bolt intervals indicated that 65% of the energy dissipation capacity is provided by bolts. Strengthened specimens exhibited significantly higher energy dissipation capacities compared to the reference specimen. However, no significant changes were observed in the energy dissipation capacities of the specimens with the same bolt interval but steel plates of different thicknesses. We, therefore, concluded that the thickness of expanded steel plates does not have a significant impact on the mechanical properties of the walls; however, specimens with a bolt interval of 150 mm exhibited greater mechanical properties compared to the specimens with a bolt interval of 400 mm. Based on these findings we found that the impact of the bolt interval on the strength and behaviors of the members is higher than the impact of steel plate thickness.
- The ductility capacity of the reference wall specimen built with vertical-hole bricks, which are brittle construction materials, was significantly lower compared to the specimens strengthened with expanded steel plates. Compared to the reference specimen, strengthened specimens exhibited an average of 20% higher stiffness, 126% higher ductility, 410% higher energy dissipation capacity, and 72% higher load-carrying capacity.

According to the definition of the diagonal compression test in the ASTM E519, 1/8 of the side span of the neighboring edges to the diagonal loading point are fastened by loading shoes and other parts of the edges are set free during the loading. It is assumed that the wall

sides contact with only 12.5% of the lateral-vertical peripheral tie system under the lateral loading and therefore, load applies to the wall through this contact area. In real cases, however, the contact area of the masonry walls with the lateral and vertical peripheral ties can be higher than the estimated value in the ASTM E519 due to the deformations under earthquake effect. The compression tests performed in the current study showed that the contact area of the wall sides with the frame which represents the lateral-vertical peripheral tie system was 60%.

Acknowledgements

The current study is based on the data of the Master's thesis of Ezatullah Ahmadzai, which was supervised by Asst. Prof. Zeynep Yaman and Asst. Prof. Alper Cumhur.

We would like to take the opportunity and thank Asst. Prof. M. Zeki Özyurt, Assoc. Prof. Elif Ağcakoca, M.Eng. Mohammad Saber Sadid, Fibreton Board Member M.Eng. Muhammed Maraşlı and FİBROBETON (<https://www.fibrobeton.com.tr/>) company for their contributions to this study.

Funding

The authors received no financial support for the research, authorship, and/or publication of this manuscript.

Conflict of Interest

The authors declared no potential conflicts of interest with respect to the research, authorship, and/or publication of this manuscript.

REFERENCES

- Abdulsalam B, Ali AH, ElSafty A, Elshafey N (2021). Behavior of GFRP strengthening masonry walls using glass fiber composite anchors. *Structures*, 29, 1352-1361.
- Ağcakoca E, Bıyıklıoğlu E (2020). Experimentally and numerically investigating the performances of aramid fiber-reinforced steel beams under impact loadings. *Arabian Journal for Science and Engineering*, 45(10), 8053-8068.
- Arslan ME, Ağcakoca E, Senturk M (2020). Effects of plaster thicknesses on cyclic behavior of infill walls with different materials. *Periodica Polytechnica Civil Engineering*, 63(3), 678-679.
- ASTM E519/E519M-10 (2010). Standard Test Method for Diagonal Tension (shear) in Masonry Assemblages. American Society for Testing and Materials, West Conshohocken, Pennsylvania, U.S.A.
- Ateş T (2013). İçten ve Dıştan Donatılı Püskürtme Beton ile Güçlendirilen Yığma Duvarların Düzlem Dışı Tekrarlı Yük Altındaki Davranışı. *PhD thesis*, Gazi University, Ankara, Turkey. (in Turkish)
- Aydın AC, Yaman Z, Ağcakoca E, Kiliç M, Maali M, Dizaji AA (2020). CFRP effect on the buckling behavior of dented cylindrical shells. *International Journal of Steel Structures*, 20(2), 425-435.
- Aykaç B, Özbek E, Babayani R, Baran M, Aykaç S (2017). Seismic strengthening of infill walls with perforated steel plates. *Engineering Structures*, 152, 168-179.

- Babayani R (2012). Delikli Çelik Levhalarla Güçlendirilmiş Tuğla Duvarların Tersinir Tekrarlanır Yükler Altındaki Davranış ve Dayanımı, *MSc thesis*, Gazi University, Ankara, Turkey. (in Turkish)
- Bahçekapılı S (2003). Mevcut betonarme yapıların depreme karşı güvenliğini belirleme yöntemleri, *M.Sc. Thesis*. Sakarya University, Sakarya, Turkey. (in Turkish)
- Baran M, Aktaş M, Aykaç S (2014). Sıvanmış tuğla dolgu duvarların şerit beton/betonarme panellerle güçlendirilmesi. *Gazi Üniversitesi Mühendislik Mimarlık Fakültesi Dergisi*, 29(1), 23-33. (in Turkish)
- Budak A, Uysal H, Aydın AC (2004). Kırsal yapıların deprem karşısındaki davranışı. *Atatürk Üniversitesi Ziraat Fakültesi Dergisi*, 35(3-4). (in Turkish)
- Chen W, Yeh K, Hwang J, Lu C (2012). Out-of-plane seismic behaviour and CFRP retrofitting of RC frames infilled with brick walls. *Engineering Structures*, N.T.U. Taiwan, 34, 213-224.
- Cheng S, Yin S, Jing L (2020). Comparative experimental analysis on the in-plane shear performance of brick masonry walls strengthened with different fiber reinforced materials. *Construction and Building Materials*, 259, 120387.
- Corradi M, Castori G, Borri A (2020). Repairing brickwork panels using titanium rods embedded in the mortar joints. *Engineering Structures*, 221, 111099.
- Cumhur A (2016). Tuğla Dolgu Duvarların Genişletilmiş Çelik Levhalar ile Güçlendirilmesi. *PhD thesis*, Sakarya University, Sakarya, Turkey. (in Turkish)
- Cumhur A, Altundal A, Kalkan I, Aykac S (2016). Behaviour of brick infill walls strengthened with expanded steel plates. *Bulletin of Earthquake Engineering*, 14(11), 3231-3258.
- Ehsani MR, Saadatmanesh H, Velazquez-Dimas JI (1999). Behavior of retrofitted URM walls under simulated earthquake loading. *Journal of Composites for Construction*, 3(3), 134.
- Erköseoğlu G (2014). Seismic Performance of Confined Masonry Construction. *MSc thesis*, Middle East Technical University, Ankara, Turkey.
- FEMA 306 (1998). Evaluation of earthquake damaged concrete and masonry wall buildings. Federal Emergency Management Agency, Redwood City, California, U.S.A.
- Güvenir E (2019). Yığma Yapıların Bölgesel Risk Dağılımının Belirlenmesi için Alternatif Hızlı Tarama Yönteminin Geliştirilmesi. *MSc thesis*, Hacettepe University, Ankara, Turkey. (in Turkish)
- Hamdy G, Kamal O, Al-Hariri O, El-Salakawy T (2018). Plane and vaulted masonry elements strengthened by different techniques—Testing, numerical modeling and nonlinear analysis. *Journal of Building Engineering*, 15, 203-217.
- Hejazi F, Noorzai J, Ali AAA, Jaafar MS (2015). Seismic analysis of interlocking mortarless hollow block. *Challenge Journal of Structural Mechanics*, 1(1), 22-26.
- İstegün B, Subaşı A, Çelebi E (2018). Sismik tekstil ile güçlendirilmiş düşey delikli yığma tuğla ve bims blokların üç noktalı kesme deneyi. *Academic Platform-Journal of Engineering and Science*, 7(2), 222-228. (in Turkish)
- Johansson P, Geving S, Hagentoft CE, Jelle BP, Rognvik E, Kalagasidis AS, Time B (2014). Interior insulation retrofit of a historical brick wall using vacuum insulation panels: Hygrothermal numerical simulations and laboratory investigations. *Building and Environment*, 79, 31-45.
- Kalali A, Kabir MZ (2012). Cyclic behaviour of perforated masonry walls strengthened with glass fiber reinforced polymers. *Scientia Iranica*, 19(2), 151-165.
- Kalkan N (2008). Düzlem Dışı Tersinir Yüklenen Yığma Yapıların Donatılı Püskürtme Beton ile Güçlendirilmesi. *PhD thesis*, Gazi University, Ankara, Turkey. (in Turkish)
- Karaton M, Çanakçı K (2021). Yığma duvarların mikro modellemesinde harcın çekme dayanımı ve kayma gerilmesi iletim katsayısının çözümler üzerindeki etkisinin incelenmesi. *Dicle Üniversitesi Mühendislik Fakültesi Mühendislik Dergisi*, 12(1), 175-185. (in Turkish)
- Kaya F (2013). Yığma Yapıların Polipropilen Lifli Kuru Karışım Püskürtme Beton ile Güçlendirilmesi. *MSc thesis*, Süleyman Demirel University, Isparta, Turkey. (in Turkish)
- Koç V (2016). Depreme maruz kalmış yığma ve kırsal yapı davranışlarının incelenerek yığma yapı yapımında dikkat edilmesi gereken kuralların derlenmesi. *Çanakkale Onsekiz Mart Üniversitesi Fen Bilimleri Enstitüsü Dergisi*, 2(1), 36-57. (in Turkish)
- Korkmaz A (2014). Farklı yapısal malzeme özelliklerinin yığma yapı davranışına etkisi. *Nevşehir Bilim ve Teknoloji Dergisi*, 3(1), 69-78. (in Turkish)
- Koutas L, Bousias SN, Triantafyllou TC (2014). Seismic strengthening of masonry-infilled RC frames with TRM: Experimental study. *Journal of Composites for Construction*, 19(2).
- Leeanansaksiri A, Panyakapo P, Ruangrassamee A (2018). Ascorbate, seismic capacity of masonry infilled RC frame strengthening with expanded metal ferrocement. *Engineering Structures*, 159, 110-127.
- Maali M, Kılıç M, Yaman Z, Ağcakoca E, Aydın AC (2019). Buckling and post-buckling behavior of various dented cylindrical shells using CFRP strips subjected to uniform external pressure: Comparison of theoretical and experimental data. *Thin-Walled Structures*, 137, 29-39.
- Marques AI, Ferreira JG, Candeias P, Veiga MDR (2022). Experimental evaluation of brick masonry walls strengthened with TRM (textile reinforced mortar) renders. *Buildings*, 12(6), 840.
- Mezrea PE, İspir M, Balci IA, Bal IE, İlki A (2021). Diagonal tensile tests on historical brick masonry walls strengthened with fabric reinforced cementitious mortar. *Structures*, 33, 935-946.
- Mosallam AS (2007). Out-of-plane flexural behavior of unreinforced red brick walls strengthened with FRP composites. *Composites Part B: Engineering*, 38(5-6), 559-574.
- Orullkaya H A (2019). Mevcut Yığma Yapıların Deprem Yüklerine Karşı Güçlendirilmesinde Püskürtme Beton Kullanımı. *MSc thesis*, Namık Kemal University, Tekirdağ, Turkey. (in Turkish)
- Ozsayın B, Yılmaz E, İspir M, Ozkaynak H, Yuksel E, İlki A (2011). Characteristics of CFRP retrofitted hollow brick infill walls of reinforced concrete frames. *Construction and Building Materials*, 25(10), 4017-4024.
- Özbek E, Can H (2012). Dolgu tuğla duvarların çelik profillerle güçlendirilmesi. *Gazi Üniversitesi, Mühendislik Mimarlık Fakültesi Dergisi*, 27(4), 921-929. (in Turkish)
- Özbek E (2015). Delikli Çelik Levhalarla Güçlendirilmiş Tuğla Duvarların Çerçeve Davranışı Üzerindeki Etkisi. *PhD thesis*, Gazi University, Ankara, Turkey. (in Turkish)
- Özbek E, Aykaç B, Can H, Kalkan İ, Aykaç S (2019). Delikli levhalarla güçlendirilmiş tuğla duvarların hesabı için öneriler. *Gazi Üniversitesi Mühendislik Mimarlık Fakültesi Dergisi*, 34(1), 1-16.
- Özdemir H, Eren İ (2011). Bölme duvarının ve bölme duvar güçlendirilmesinin çerçeve davranışına etkisi. *İTÜDERGİSİ/d*, 8(6), 133-145. (in Turkish)
- Özmen R (2018). Tuğla Duvarların Çelik Levha/Şerit Kullanılarak Kesme Davranışının İyileştirilmesi. *MSc thesis*, Gazi University, Ankara, Turkey. (in Turkish)
- Özyurt MZ, Mohammadi M, Cumhur A (2020). Genişletilmiş çelik levhalarla güçlendirilmiş blok tuğla duvarlarda bulon aralığının dayanımı ve davranış üzerindeki etkisi. *Avrupa Bilim ve Teknoloji Dergisi*, 365-373. (in Turkish)
- Rebello F, Figueiredo A, Correia Lopes G, Ferreira TM, Vicente R (2021). Development of retrofitting solutions: remedial wall ties for masonry enclosure brick walls. *Buildings*, 11(1), 28.
- Sevil T, Baran M, Canbay E (2010). Tuğla dolgu duvarların B/A çerçevesi yapıların davranışına etkilerinin incelenmesi; deneysel ve kuramsal çalışmalar. *International Journal of Engineering Research and Development*, 2(2), 35-42. (in Turkish)
- Seydanlıoğlu M (2013). Delikli çelik levhalarla güçlendirilmiş tuğla duvarların tekdüze yükler altındaki davranışı. *MSc thesis*, Gazi University, Ankara, Turkey. (in Turkish)
- Tekeli H, Akyürek O, Deniz M, Hersat E, Kara N, Tosun U (2014). Betonarme çerçevede dolgu duvarların hasır çelik donatılı siva ile güçlendirilmesi. *BEU Journal of Science*, 3(2), 179-191. (in Turkish)
- TS EN 772-1+A1 (2015). Methods of test for masonry units - Part 1: Determination of compressive strength. Turkish Standards Institution, Ankara, Türkiye.
- Zhu H, Wan KT, Satekenova E, Zhang D, Leung CK, Kim J (2018). Development of lightweight strain hardening cementitious composite for structural retrofit and energy efficiency improvement of unreinforced masonry housings. *Construction and Building Materials*, 167, 791-812.